

Probing Solutions for Logic Analyzers

Product Overview

Create a Quality Connection to Your Target System

To make sure you have the tools for dependable state and timing measurements, no matter what mix of chip packages, test ports and probes your application requires, we've created the largest line of probing solutions in the industry.

Accurate measurements start with reliable probing. Agilent Technologies offers a wide variety of probing accessories to support your measurement needs, making it easy to connect your Agilent logic analyzer to your design.

Each is designed for a specific measurement need because the physical and electrical quality of the connection can mean the difference between a good measurement and a bad one.

About this Document

To assist you in choosing the best state/timing probing solution for your particular target, this document will consider the following:

- Chip packaging, test ports
- Special physical and electrical considerations
- Other accessories and options

Other Reference Documents

For information on probes and accessories for the other related Agilent Technologies logic analysis system products listed below, please refer to "Related Information" in this document:

- Pattern generators
- Emulators
- Oscilloscopes

Table of Contents

Reliable Connections	
Ensure Accuracy	2
Which Logic Analyzer?	3
Quick Selection Guide	4
Selecting the Optimum Probing Strategy	5
For All Agilent Logic Analyzers with 40-pin Pod Connectors	5
For All Agilent Logic Analyzers with 90-pin Pod Connectors	7
For the Agilent 16517A and 16518A Logic Analysis Modules	8
General-Purpose Probing	9
For All Agilent Logic Analyzers with 40-pin Pod Connectors	9
General-Purpose Probing	12
QFP Package Probing	14
Designing and Probing with Target Connections	17
Normal-Density, Medium-Performance Applications	17
For All Agilent Logic Analyzers with 40-pin Pod Connectors	18
Probing Individual Pins of High-Density Connectors	30
Designing and Probing with Target Connections	31
Designing and Probing with Target Connections	32
Agilent Logic Analyzers with 90-pin Pod Connectors	32
Agilent 16760A 1.5 Gbits/Sec Logic Analyzer Module	37
Agilent Logic Analyzers with 90-pin Pod Connectors	38
General-Purpose Probing	40
Agilent Logic Analyzers with 90-pin Pod Connectors	40
Agilent 16517A/16518A 1 GHz State / 4 GHz Timing	45
Ordering Information	47
Related Information	52
Support, Services, and Assistance ..	53



Reliable Connections Ensure Accuracy

- **Impedance**

High input impedance ensures minimum intrusion on your circuit. Although many probes might be acceptable for lower frequencies, capacitive loading becomes significant at higher frequencies. The Agilent Technologies probing products perform over a wide frequency spectrum.

- **Ruggedness**

Probes with quality mechanical design provide solid electrical connections. Intermittent open circuits would only add one more variable to your debugging equation. Agilent probes are mechanically designed to relieve strain and ensure rugged, reliable connection.

- **Immunity to Noise**

Electromagnetic noise can corrupt data captured by the logic analyzer. Agilent probing solutions are designed for a high immunity to transient noise.

- **Performance**

Agilent logic analyzers have front-end circuitry that supports the state and timing specifications of the analyzer. This circuitry, together with the Agilent probing solutions described in this document, will accurately capture the target signals at the specified clock rates.

Signal Frequency Content Drives Probing Solutions

Faster clock rates demand tighter timing tolerances, such as setup and hold specifications. Systems with faster clock rates usually have shorter rise and fall times. Signals with shorter transition times have more high frequency content and are more susceptible to high frequency analog problems such as cross talk, reflections, ground bounce, noise and emissions. Susceptibility of a system to analog problems relates to the transition times of the signals, not the clock rate. A system with slow transition times cannot have high clock rates. However, it is possible for a system with slower clock rates to have signals with very fast transition times.

General-purpose probing solutions provide the analog bandwidth required to run each logic analyzer module at its maximum clock rate. The high input impedance of these probes, especially at high frequencies, presents a minimal load to most systems. Systems that are operating with little margin should be designed with consideration for both the system components and the input impedance of the probing solution being used during debug. Input impedance specifications or equivalent load diagrams can be found for each of the probing solutions described in this document.

For measurements at state speeds above 400 Mbits/second, and for differential signals, Agilent has developed a new connectorless probing system that is used with the Agilent 16753A, 16754A, 16755A, 16756A, and 16760A logic analyzer measurement modules. This probing system features capacitive loading of only 0.7 pF. Refer to pages 32-33 for information on this probing system.

Other Considerations

Physical connection compatibility between various Agilent probes may allow you to mix and match a variety of probes and accessories. However, a probe accessory designed for slower clock speeds will not deliver high-speed target performance simply because it is used with a higher speed analyzer module. Also, the serial connection of multiple probe leads and/or accessories will degrade signal integrity.

Which Logic Analyzer?

Agilent logic analyzers have two methods of connection to the probes. One uses a 3M-style connector with 2 rows of 20 pins on 0.1-inch centers, as illustrated in figure 1. Probes for these analyzers are identified in this document as “for analyzers with 40-pin pod connectors.”

The other style uses a 90-pin, high-density connector, as illustrated in figure 2. Probes for these analyzers are identified in this document as “for analyzers with 90-pin pod connectors.”

Currently available Agilent logic analyzers in these two groups are as follows:

40-pin pod connector	90-pin pod connector
1670 series logic analyzers	16753A
1680, 1690 series logic analyzers	16754A
16710A	16755A
16711A	16756A
16712A	16760A
16715A	
16716A	
16717A	
16740A	
16741A	
16742A	
16750B	
16751B	
16752B	

The Agilent 16517A and 16518A (discontinued) do not use either of these connection systems. For discussions of the accessories available for the 16517A and 16518A, refer to pages [8] and [45-46]. [Page numbers refer to the current version.]

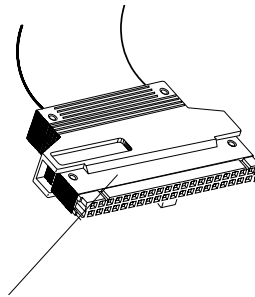


Figure 1. 40-pin pod connector

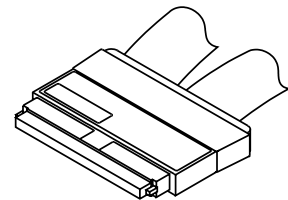


Figure 2. 90-pin pod connector.

Quick selection guide

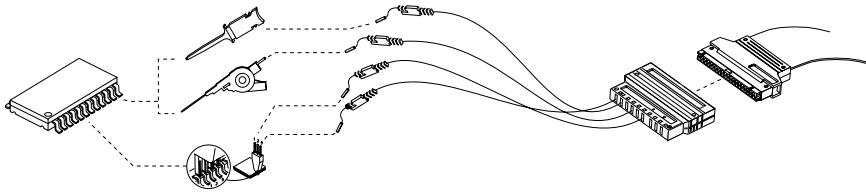
For logic analyzer pod connection	Connection to system under test	Single-ended* or differential	Number of channels	Agilent model number or part number	Page
40-pin	Flying leads	Single-ended	17	01650-61608	9
40-pin	100-pin connector	Single-ended	34	E5385A	23
40-pin	38-pin connector	Single-ended	34	E5346A	23
40-pin	38-pin connector	Single-ended, low voltage	34	E5339A	23
40-pin	38-pin connector	Single-ended, no isolation networks	34	E5351A	27
90-pin	Flying leads	Single-ended	17	E5382A	40
90-pin	Flying leads	Differential	17	E5381A	42
90-pin	Soft touch connectorless	Single-ended	34	E5390A	32
90-pin	Soft touch connectorless	Differential	17	E5387A	32
90-pin	100-pin connector	Single-ended	34	E5378A	36
90-pin	100-pin connector	Differential	17	E5379A	36
90-pin	38-pin connector	Single-ended	34	E5380A	38

* Isolation networks are included unless designated otherwise.

Selecting the Optimum Probing Strategy

For All Agilent Logic Analyzers with 40-pin Pod Connectors

Connecting to Individual IC Pins or Test Points



Advantages

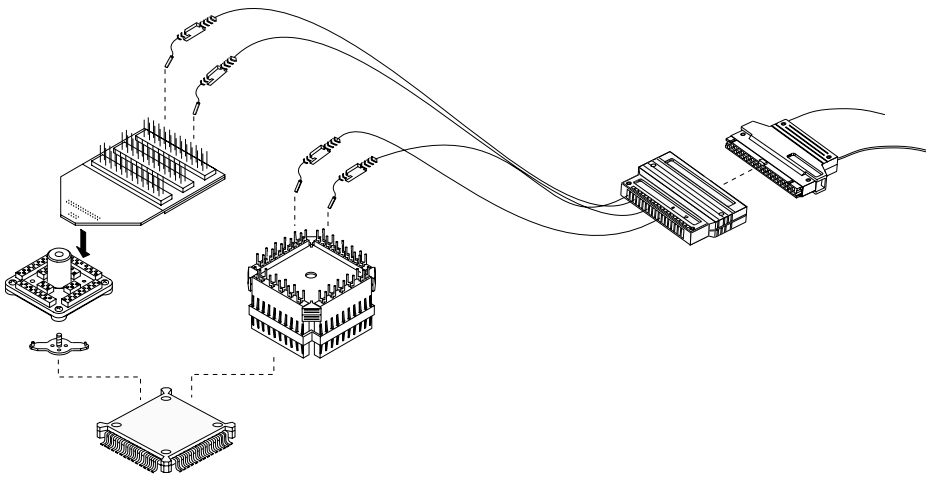
Most flexible method.
Flying-lead probes are included with logic analyzer module.

Limitations

Can be time-consuming to connect a large number of channels.
Least space-efficient method.
Some accessories may compromise probe performance.

Go to page 9 for a discussion of Agilent's flying-lead logic analysis probes and accessories for logic analyzers with 40-pin pod connectors.

Connecting to all the Pins of a Specific Package



Advantages

Rapid access to all pins of fine-pitch QFP package.
Very reliable connections.

Limitations

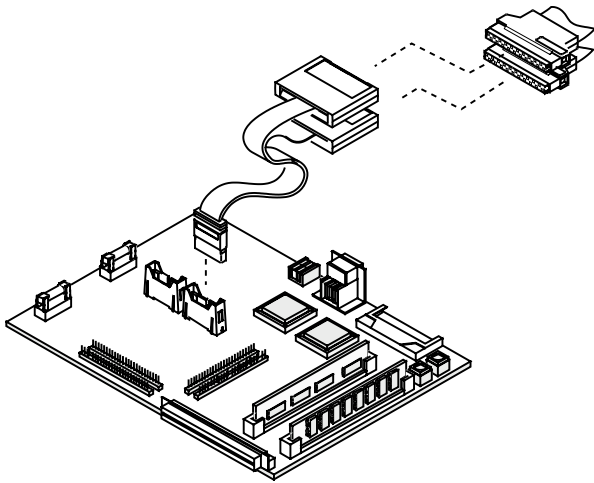
Requires minimal keep-out area.
Requires some time for installation of retainer on IC package.
May compromise probe performance.

Go to page 14 for a discussion of Agilent's QFP package probing solutions for logic analyzers with 40-pin pod connectors.

Selecting the Optimum Probing Strategy

For All Agilent Logic Analyzers with 40-pin Pod Connectors

Designing Connectors Directly into the Target System



Advantages

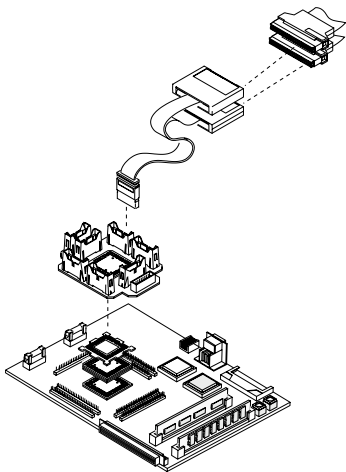
Very reliable connections.
Saves time in making multiple connections.
Least amount of board space required for large number of channels.

Limitations

Requires advanced planning in the design stage.
Requires some dedicated board space.
Moderate incremental cost.

Go to page 17 for a discussion of Agilent's target connector solutions for logic analyzers with 40-pin pod connectors.

Using Processor/Bus Specific Probes



Advantages

Easiest and fastest connections to supported processors and buses.

Limitations

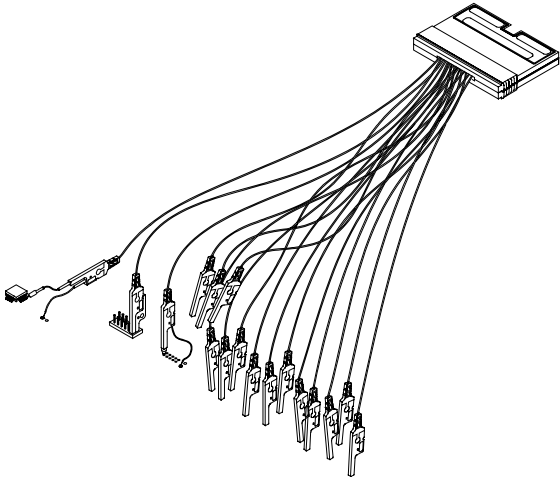
Moderate to significant incremental costs.
Only usable for the specific processor or bus.

Refer to *Processor and Bus Support for Agilent Technologies Logic Analyzers*, publication number 5966-4365E at: <http://www.agilent.com/find/pnbs>. That document will tell you what additional probing accessories you need to connect logic analyzers with 40-pin pod connectors to the analysis probes.

Selecting the Optimum Probing Strategy

For all Agilent Logic Analyzers with 90-pin Pod Connectors

Connecting to Individual IC Pins, Test Points, Browsing or Solder Attach to Components, Traces or VIAs



Advantages

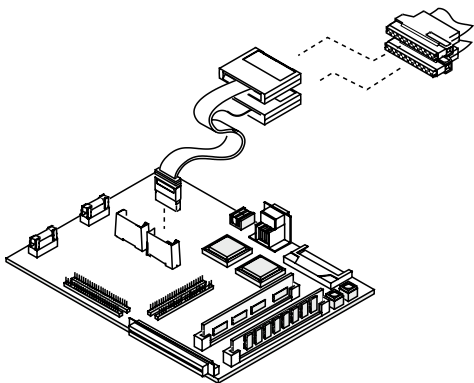
Most flexible method.
 Convenient for picking up signals that may not be grouped conveniently on your board with buses routed to connectors (example: system clock, interrupts).

Limitations

Time-consuming to connect large number of channels.
 Requires more board space, for large number of channels.
 Some accessories may degrade probe performance at high speeds.

Go to page 40-43 for a discussion of Agilent's flying lead probe sets for logic analyzers with 90-pin pod connectors.

Designing Connections Directly into the Target System



Advantages

Save time in making multiple connections.
 Least amount of board space required for large number of channels.

Limitations

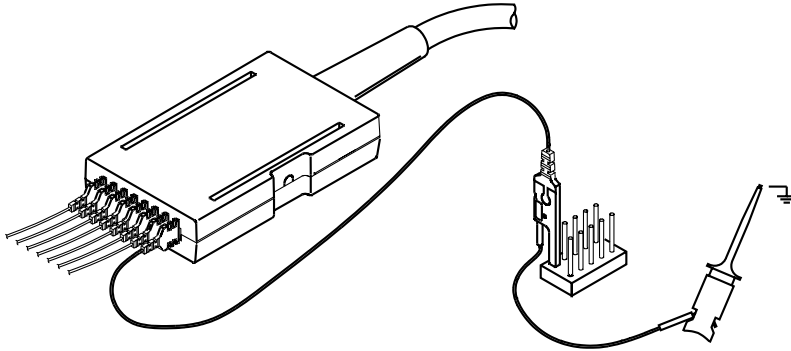
Requires advanced planning in the design stage.

Go to page 36 for the target connector probing solutions for logic analyzers with 90-pin pod connectors. Go to page 32 for connectorless solutions for logic analyzers with 90-pin pod connectors.

Selecting the Optimum Probing Strategy

For the Agilent 16517A and 16518A Logic Analysis Modules

Connecting to Individual IC Pins or Test Points



Advantages

Very low capacitance.

Limitations

No high-density probing solutions available for the 16517A and 16518A.

Go to page 45 for probing solutions for the Agilent 16517A and 16518A logic analysis modules.

General-Purpose Probing

For All Agilent Logic Analyzers with 40-pin Pod Connectors

When maximum signal fidelity is required or only a few lines may need to be probed, the 16-channel lead sets shipped with the Agilent logic analysis systems can provide a quick and convenient method for probing.

Logic Analysis General-Purpose Probes

General-purpose probing requires connecting probe leads to individual signal lines. This method is most convenient for a small to moderate number of signals, very flexible, and can be used in conjunction with other probing methods.

Note: Any probed signal line must be able to supply a minimum of 600 mV to the probe with the specified loading.

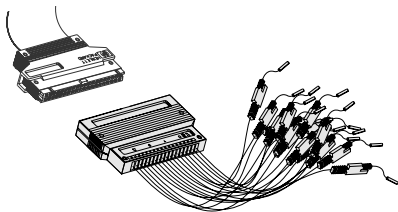


Figure 4. Sixteen-channel probe lead set (part number 01650-61608)

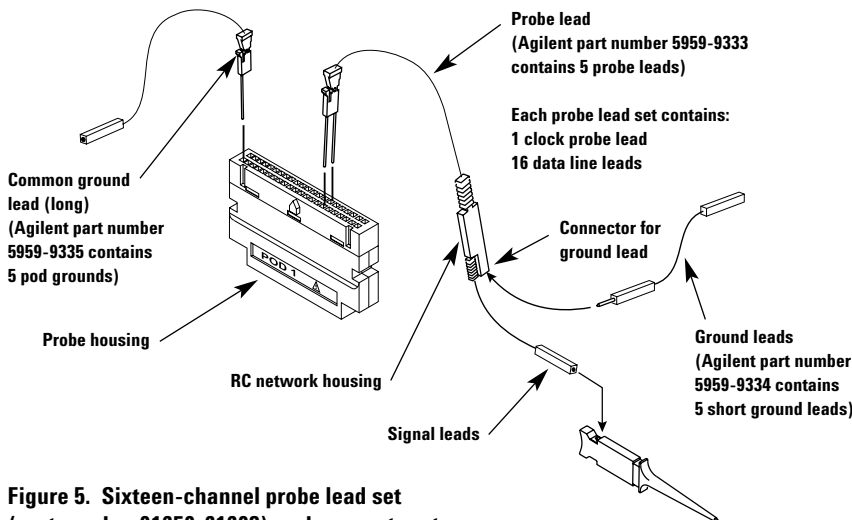


Figure 5. Sixteen-channel probe lead set (part number 01650-61608) replacement parts

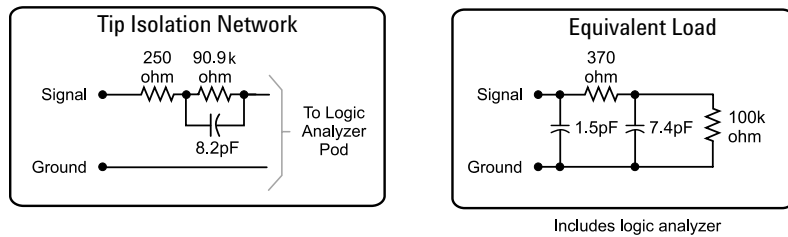


Figure 3. Probe tip isolation network and equivalent load

The Standard Probing System

The standard probing system consists of IC clips, probe leads, probe housing and probe cable. Because it is passive, the standard probing system is smaller, lighter, and much easier to use than active probing systems. This passive probing system is similar to a probing system used on a high frequency oscilloscope. It consists of an isolation network (as shown in figure 3) at the probe tip and a shielded resistive transmission line. The advantages of this system are:

- High input impedance. See figure 3.
- Signal ground at the probe tip for high-speed signals.
- Inexpensive, removable probe tip assemblies.

Probe Leads and Lead Sets

Probe leads are configured into lead sets, which can probe 16 data channels with ground, one clock channel, and a common ground. A 16-channel probe lead set (part number 01650-61608) is shown in figure 4, along with the replacement part numbers for individual components in figure 5.

Each probe lead is a 12-inch, twisted-pair cable connected to the probe cable at the probe housing (see figure 5). The probe tip includes a signal lead, a connector for a ground lead, and the isolation network.

The signal and ground leads can be connected directly to the target system. This requires installing 0.63 mm (0.025 in) square pins, or round pins with a diameter of between 0.66 mm (0.026 in) and 0.84 mm (0.033 in) directly on the board. An IC test clip can also be used. The same specifications apply for the pin dimensions of the test clip. (See figure 8 for IC test clips available from Agilent.)

General-Purpose Probing

For All Agilent Logic Analyzers with 40-pin Pod Connectors

IC Clips

The through-hole IC clips (part number 5959-0288, containing 20 IC clips) have a single hook that fits around IC pins and component leads. The surface-mount device IC clip with twin hooks (part number 5090-4833, containing 20 IC clips) is designed for fine surface-mounted component leads. The twin hook 0.5 mm IC clip (part number 10467-68701, containing four 0.5 mm IC clips), is very useful for 0.5 mm pitch components. See figure 7.

The E2421A kit contains one each: 8-pin, 14-pin, 16-pin, 20-pin, 24-pin, and 28-pin SOIC test clips. See figure 8.

The E2422A kit contains one each: 20-pin, 28-pin, 44-pin, 52-pin, 66-pin, and 84-pin QUAD IC test adapters. See figure 8.

Grounding

There are three methods of grounding the probe system. First, the entire probe lead set can be grounded through the common ground. This requires only one connection, but is not recommended because it will cause poor signal fidelity in systems with fast transition times. The recommended method is to individually ground each probe lead. This yields optimal signal fidelity and is required for signals with faster transition times ($< 4 - 5$ ns).

For moderate rise times (greater than 2 ns), it may be acceptable to ground every other (or every fourth) ground connection to the target.

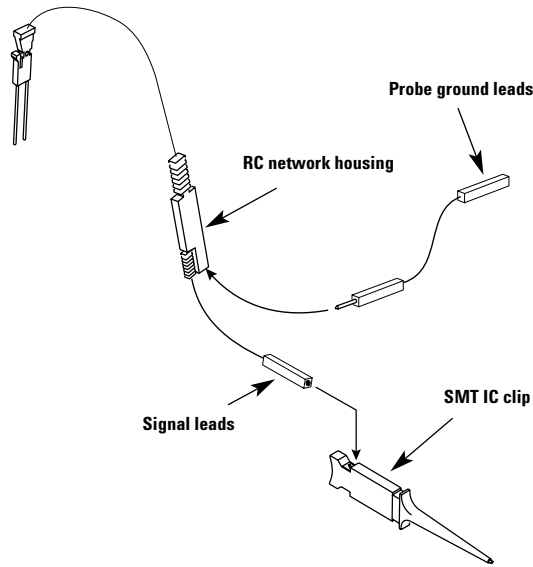


Figure 6. Connecting IC clips and ground leads to probes

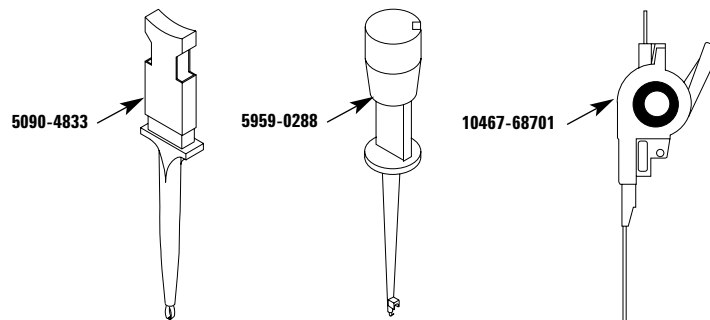


Figure 7. SMD IC clip, through-hole IC clip and 0.5 mm IC clip

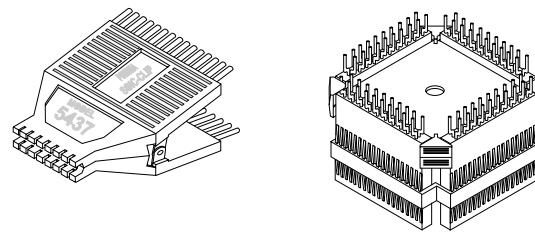


Figure 8. Typical IC test clips available in E2421A SOIC kit (left) and E2422A QUAD kit (right)

General-Purpose Probing

For All Agilent Logic Analyzers with 40-pin Pod Connectors

Signal Line Loading

Any probed signal line must be able to supply a minimum of 600 mV to the probe tip while the probe is connected to the system. The maximum input voltage of each probe is ± 40 volts peak.

Probe Cables

The probe cable (see figure 9 and table 1) contains 16 signal lines and two clk lines, two +5 volt power lines, and ground lines for each of the signal/clock and power lines. All of these lines are contained in a 4.5-foot cable. The probe cable is included with the logic analyzer. The cable grounds are chassis (earth) grounds, not “floating” grounds. The two +5 volt power lines can be used to power active probing systems. Consult the specifications for the individual logic analyzers or logic analyzer cards for the maximum allowable current through each +5 volt power supply.

Caution: These +5 volt power lines MUST NOT be connected to the target’s power supply.

Caution: Be careful when using straight wire probe leads, one common ground, or RC networks located far from the target. These circumstances increase the impact of analog effects such as crosstalk and EMT susceptibility, which contribute to measurement errors.

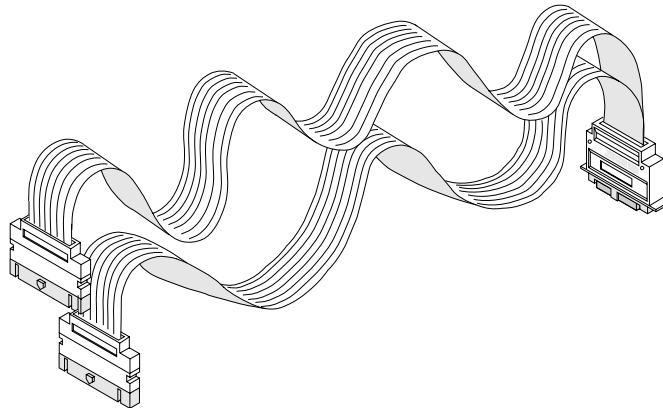


Figure 9. Logic analyzer probe cable

Logic Analyzer Stand Alone or Module	01660-61605	16555-61606	16710-61603	16715-61601
16550A	x			
16554A		x		
16555A/D		x		
16556A/D		x		
16557D			x	
16710A			x	
16711A			x	
16712A			x	
16715A				x
16716A				x
16717A				x
16718A				x
16719A				x
16740/41/42A				x
16750B				x
16751B				x
16752B				x
16706 Series			x	
1680 Series				x
1690 Series				x

General-Purpose Probing

Wedge Adapters

The Agilent Technologies Wedge technology provides very reliable probing of a few channels on 0.5 mm and 0.65 mm pitch QFPs. No clear area is required around the device. Each Wedge of the probe slides between the legs of the QFP. The side of each Wedge probe contacts the package legs. An insulation core electrically isolates the sides of each Wedge (see figures 10 and 11). Various 3-signal, 8-signal, and 16-signal probes are available (see table 2).

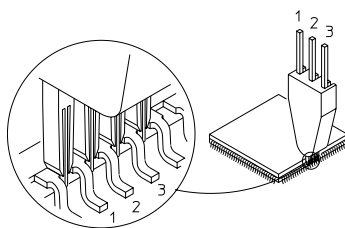


Figure 10. Three-signal Wedge electrical connection

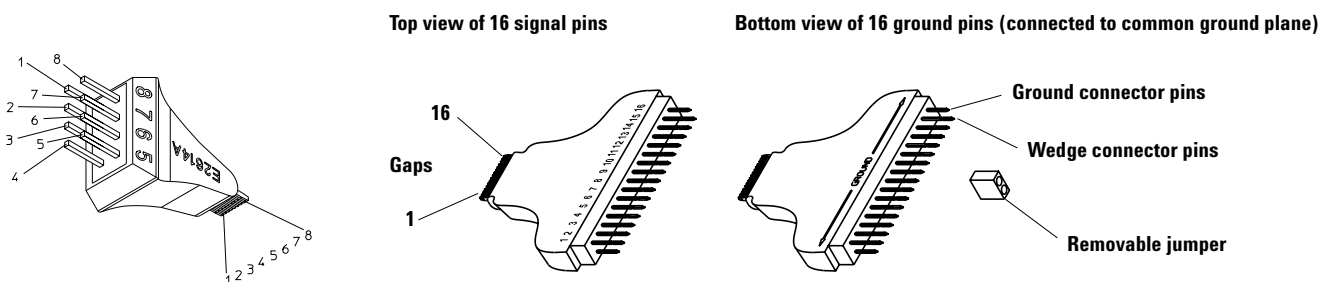


Figure 11. Eight-signal and 16-signal Wedge (16-signal Wedge has a common ground plane)

IC Leg Spacing	Number of Signals	Number of Wedges in Pack	Model Number
0.5 mm	3	1	E2613A
0.5 mm	3	2	E2613B
0.5 mm	8	1	E2614A
0.5 mm	16	1	E2643A
0.65 mm	3	1	E2615A
0.65 mm	3	2	E2615B
0.65 mm	8	1	E2616A
0.65 mm	16	1	E2644A

Table 2. Wedge probe adapter

General-Purpose Probing

Miscellaneous Probing Accessories

Additional labels can be ordered to mark test systems for specific applications. The ferrite core assembly can be added to the probe cable to suppress EMI and RFI noise that can corrupt the measurement.

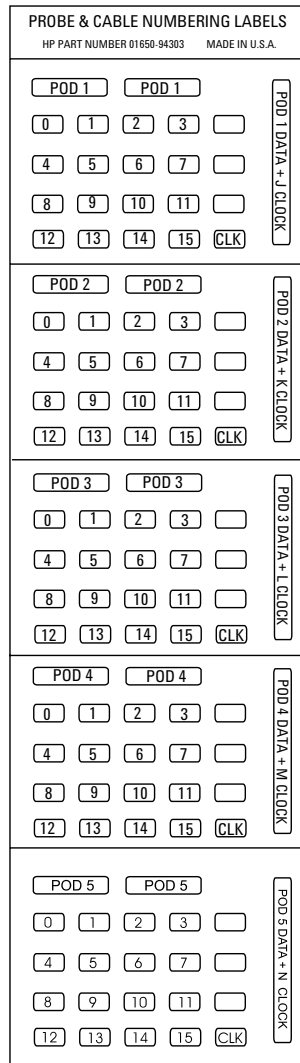


Figure 12. Labels, 01650-94303

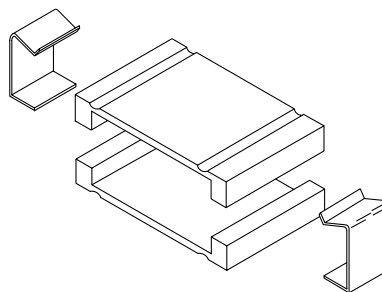


Figure 13. Ferrite core assembly, 16555-60001

QFP Package Probing

If your target contains ASICs, FPGAs, or other devices in an industry-standard QFP configuration, Agilent Technologies has a series of elastomeric probes from which you can choose. Agilent's state-of-the-art elastomeric probing technology offers an inexpensive, convenient, and reliable solution for 0.5 mm and 0.65 mm high-density TQFP/CQFP/PQFP packages.

The elastomer material on the probe makes contact between the probe and the pins of a device. Embedded on the surface of the elastomer are redundant connections for each pin, which ensure a reliable and rugged connection.

A locator tool, included with the probe adapter, correctly aligns the retainer to the device. A small amount of adhesive on the bottom of the retainer holds the retainer firmly to the device. After the adhesive is set, the locator tool can be removed. The elastomeric probe adapter then attaches to the device, held in place by the retainer and its knurled nut. Five retainers, a locator tool, and adhesive are included with each elastomeric probe adapter.

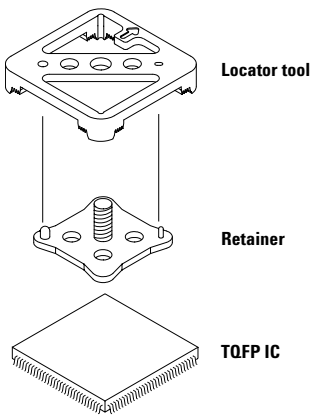


Figure 14. Locator tool aligning retainer on the device

Additional Accessories

Quarter flex adapters, shown in figure 15, are available to bring the signals from the elastomeric probe adapter to general-purpose headers for easy connection to logic analyzers, oscilloscopes, or other test equipment. Four 1/4 flex adapters are required to view all signals on a device. Each 1/4 flex adapter provides connections

to the pins on its respective side of the QFP device. Additional retainers and locator tools are also available. A kit of five retainers and adhesive is available as option #201. The locator tool is option #202. These option numbers apply to any of the listed elastomeric probe adapter model numbers, for example, Agilent E5374A #202.

Package	Pin Pitch	Elastomeric Probe Adapter	1/4 Flex Adapter
144-pin TQFP	0.5 mm	E5336A	E5340A
144-pin PQFP/CQFP	0.65 mm	E5361A	E5340A
160-pin PQFP/CQFP	0.65 mm	E5373A	E5349A
160-pin TQFP	0.5 mm	E5377A	E5349A
176-pin TQFP	0.5 mm	E5348A	E5349A
208-pin PQFP/CQFP	0.5 mm	E5374A	E5371A
240-pin PQFP/CQFP	0.5 mm	E5363A	E5371A

Table 3. Elastomeric probe adapters

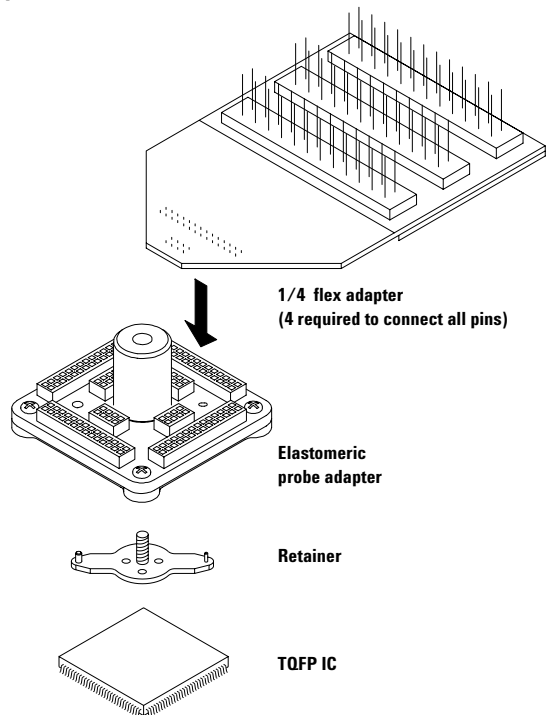


Figure 15. Elastomeric probing solution

QFP Package Probing

Electrical characteristics for this probing technology are listed in table 4.

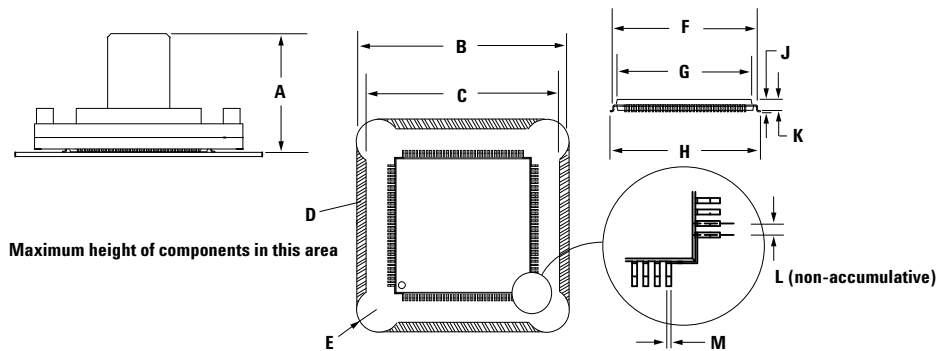
Note: The Agilent logic analyzer probes are connected to the adapters shown in this section. The target system impedance load is increased slightly (see table 4). Fast transition times (< 2 - 3 ns) may suffer some loss of signal fidelity.

The probe adapters require a minimal “keep out” area around the device, as shown in the dimension tables of figures 16 and 17.

Electrical Characteristics	Elastomeric Probe Adapter	1/4 Flex Adapter
Operating voltage	<40 V (DC + peak AC)	<40 V (DC + peak AC)
Operating current	0.5A (max)	0.5A (max)
Insulation resistance	>100 MΩ	>100 MΩ
Model Parameters		
Pin-to-ground plane capacitance (typical)		E5340A 3.0 pF first row 4.0 pF second row 6.0 pF third row E5349A 2.5 pF first row 3.5 pF second row 5.0 pF third row E5371A 2.5 pF first row 3.5 pF second row 5.0 pF third row
Pin-to-pin capacitance	0.5 pF	2 pF
Self inductance (typical)		E5340A 15 nH first row 25 nH second row 35 nH third row E5349A 20 nH first row 30 nH second row 40 nH third row E5371A 20 nH first row 30 nH second row 40 nH third row
Environmental Characteristics		
Operating temperature	0°C to 50°C	0°C to 50°C
Maximum operating humidity	75% relative humidity	75% relative humidity

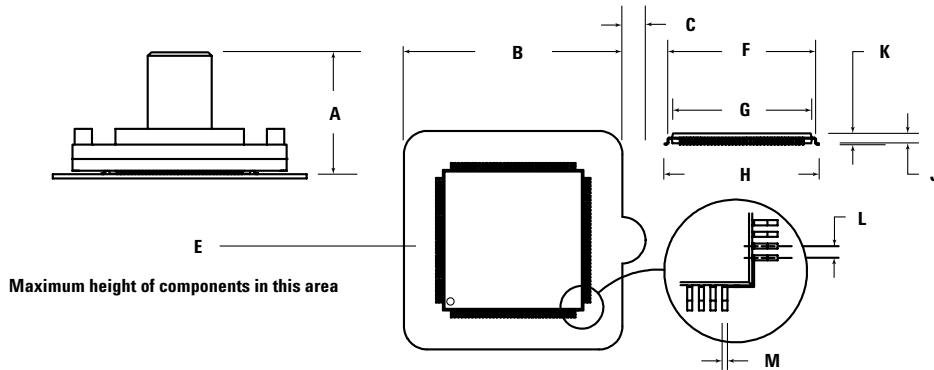
Table 4. Probe and flexible adapter electrical and environmental characteristics

QFP Package Probing



Adapter	A	B	C	D	E	F	G	H	J	K	L	M
144-Pin TQFP												
(inches)	0.674	1.240	1.130	0.055	0.138	0.827 (min)	0.795 (max)	0.866±0.008	0.057 to 0.063	0.053 to 0.057	0.0197±0.0012	0.009±0.002
(millimeters)	17.13	31.50	28.70	1.40	3.50	21.00 (min)	20.20 (max)	22.00±0.20	1.450 to 1.60	1.350 to 1.45	0.500±0.03	0.220±0.05
160-Pin TQFP												
(inches)	0.76	1.343	1.343	0	0.11	0.988 (min)	0.953 (max)	1.024±0.008	0.061 to 0.063	0.051 to 0.059	0.01965±0.001	0.0087 to 0.015
(millimeters)	19.2	34.11	34.11	0	2.79	25.09 (min)	24.20 (max)	26.00±0.20	1.550 to 1.61	1.3 to 1.5	0.50±0.03	0.220 to 0.38
176-Pin TQFP												
(inches)	0.674	1.398	1.287	0.055	0.138	0.984 (min)	0.953 (max)	1.024±0.008	0.057 to 0.063	0.053 to 0.057	0.0197±0.0012	0.009±0.002
(millimeters)	17.13	35.50	32.70	1.40	3.50	25.00 (min)	24.20 (max)	26.00±0.20	1.450 to 1.60	1.350 to 1.45	0.50±0.03	0.220±0.05

Figure 16. Elastomeric probe and package dimensions for TQFP



Adapter	A	B	C	E	F	G	H	J	K	L	M
144-Pin PQFP/CQFP											
(inches)	0.73	1.583	0.16	0.01	1.135 (min)	1.106 (max)	1.236 (max)	0.094 to 0.098	0.108 (max)	.0256±0.0012	0.009±0.002
(millimeters)	18.5	40.21	4	0.3	28.85 (min)	28.10 (max)	31.40 (max)	2.40 to 2.50	2.75 (max)	0.65±.03	0.22±0.05
160-Pin PQFP/CQFP											
(inches)	0.76	1.583	0.16	0.03	1.154 (min)	1.106 (max)	1.266 (max)	0.126 to 0.146	0.136 to 0.161	.0256±0.0012	0.009±0.002
(millimeters)	19.2	40.21	4	0.8	29.32 (min)	28.10 (max)	32.15 (max)	3.20 to 3.70	3.45 to 4.10	0.65±.03	0.22±0.05
208-Pin PQFP/CQFP											
(inches)	0.76	1.583	0.16	0.03	1.136 (min)	1.110 (max)	1.197 to 1.213	0.126 to 0.142	0.136 to 0.161	0.0197±0.0012	0.009±0.002
(millimeters)	19.2	40.21	4	0.8	28.85 (min)	28.20 (max)	30.40 to 30.80	3.20 to 3.60	3.45 to 3.60	0.50±0.03	0.22±0.05
240-Pin PQFP/CQFP											
(inches)	0.76	1.937	0.16	0.03	1.293 (min)	1.268 (max)	1.354 to 1.370	0.126 to 0.142	0.136 to 0.161	0.0197±0.0012	0.009±0.002
(millimeters)	19.2	49.20	4	0.8	32.85 (min)	32.20 (max)	34.40 to 34.80	3.20 to 3.60	3.45 to 3.60	0.50±0.03	0.22±0.05

Figure 17. Elastomeric probe and package dimensions for PQFP/CQFP

Designing and Probing with Target Connections

Normal-Density, Medium-Performance Applications

In some cases, you may not have a standard QFP package on the target available for probing access, or your device may be available only in BGA packaging.

Agilent recommends that targets with probing constraints have connectors designed into the prototype versions of the product for effective hardware and software debug. The following should be considered when designing with connectors:

- Select the appropriate connector technology for your target speed and target density.
- Carefully select all lines for routing to the connectors that may be needed for debug.
- Group the lines at each connector for your probing convenience. For example, Agilent may have written an inverse assembler for your device that has a preconfigured signal order. Before designing, refer to the documentation for this inverse assembler for essential signal lines and order.
- Keep the routing to connectors as short as possible to minimize target impact and provide accurate data.
- Examine the impact of probing isolation networks designed into the target vs. the isolation network products offered by Agilent Technologies.

An isolation network must be located between the target and the logic analyzer. It can be located on the target board in through-hole or SMT parts; or it can be attached to the logic analyzer cable with the probe leads (the isolation network is molded into the end of the probe); or the Agilent 01650-63203 isolation adapter with self contained isolation networks can be used. Probe leads can be used with connectors but are not the most convenient method. Direct connection of the connectors with the analyzer cable (isolation network parts on the target) or with a probe or isolation adapter is the faster, more convenient method.

Designing and Probing with Target Connections

For All Agilent Logic Analyzers with 40-pin Pod Connectors

Low Density, Moderate Performance

Solutions shown in the “High-Density, High-Performance” (page 23) section of this document can be used in place of the solutions described here. Agilent recommends standard 0.1 inch center connectors for normal density applications if the loading/speed is not a significant issue. Many of these items are available from 3M or Agilent (see table 5). See the “Related Information” section at the end of this document for 3M address information.

Direct Connection through Isolation Adapter

Isolation adapters (Agilent part number 01650-63203) that connect to the end of the probe cable are designed to perform two functions. The first is to reduce the number of pins required for the header on the target board from 40 pins to 20 pins. This process reduces the board area dedicated to the probing connection. The second function is to provide the proper RC networks in a very convenient package. Figure 18 illustrates how the isolation adapter physically connects to the target system and the equivalent load of the isolation adapter connected to an Agilent Technologies logic analyzer. Figures 19 and 20 show the pinout diagrams for the probe cable and the isolation adapter, respectively. There are two 20-pin connectors, along with their Agilent Technologies and 3M part numbers, listed in table 5.

Note: The Agilent 01650-63203 saves space by using a common ground (see figure 20). This will impact signal fidelity, especially faster transition times (< 4 - 5 ns).

Agilent Part Number	3M Part Number	Connector Description
1251-8106	2520-6002	20-Pin, low-profile (straight)
1251-8473	2520-5002	20-Pin, low-profile (right-angle)

Table 5. Twenty-pin connectors for fixed configuration probing. (Requires isolation adapter)

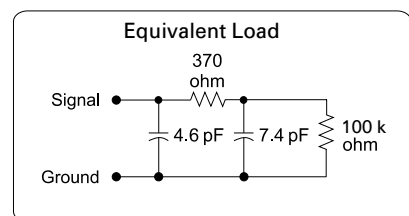
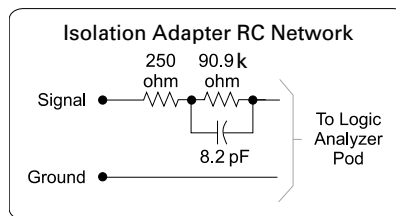
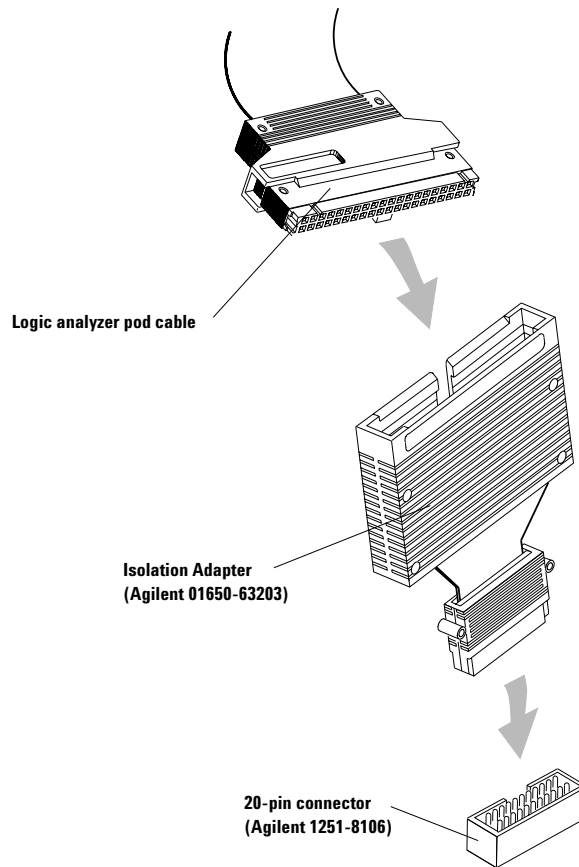


Figure 18. Isolation adapter (01650-63203) and equivalent load

Designing and Probing with Target Connections

For All Agilent Logic Analyzers with 40-pin Pod Connectors

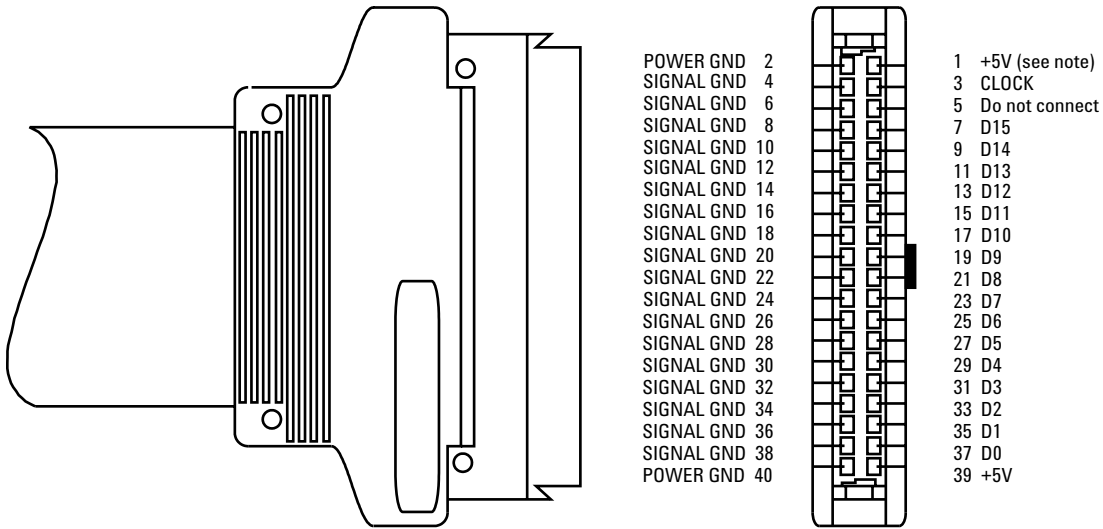


Figure 19. Pinout for probe cable

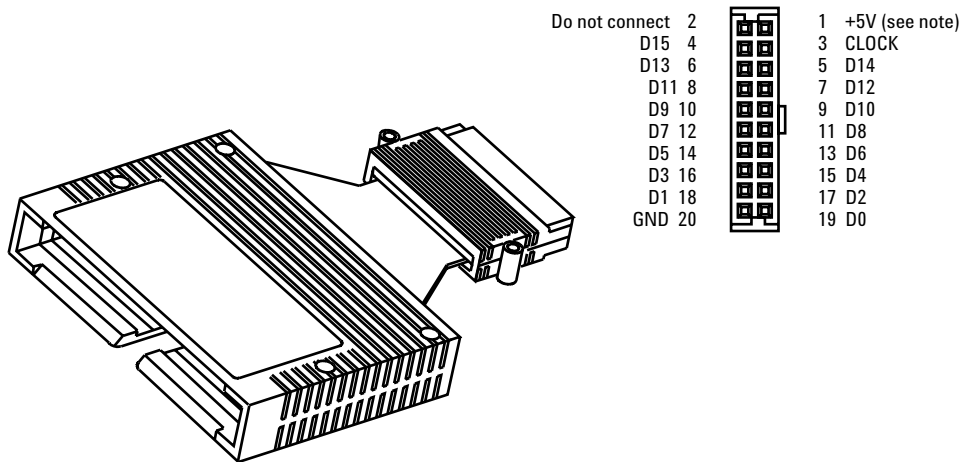


Figure 20. Pinout for 100 kΩ isolation adapter (Agilent part number 01650-63203)

Note: +5V is supplied from the logic analyzer to provide power for analysis probes and demo boards. **DO NOT connect these pins to a +5V supply in the target system!**

Designing and Probing with Target Connections

For All Agilent Logic Analyzers with 40-pin Pod Connectors

Direct Connection through 40-Pin Connectors

The probe cable also can be plugged directly into the various 40-pin connectors shown in table 6, but proper isolation networks must be installed directly onto the target system board (see figure 21 for the 40-pin connector pinout).

Agilent Technologies offers a 12-pin SMT (Agilent part number 5062-7396), which provides six isolation networks, as shown in figure 22. Three of these SMTs are required for each probe cable.

Discrete components can also be used for the proper isolation network. See figure 24 for an equivalent load diagram for the isolation networks.

Note that the effective input capacitive lead of an isolation network using discrete components is a function of the layout geometry and the parasitic capacitance of the input series damping resistor.

Agilent Part Number	3M Part Number	Connector Description
1251-8828C	2540-6002	40-Pin, low-profile (straight)
1251-8158	2540-5002	40-Pin, low-profile (right-angle)
1251-8831	3432-6302	40-Pin, with long latches (straight)
1251-8931	3432-5302	40-Pin, with long latches (right-angle)

Table 6. Forty-pin connectors for fixed configuration probing. (Requires isolation network installed on target board)

Agilent Part Number	Package Type
5062-7396	SMT, 12-pin, provides 6 isolation networks (3 SMTs required for each probe cable)

Table 7. Available isolation networks

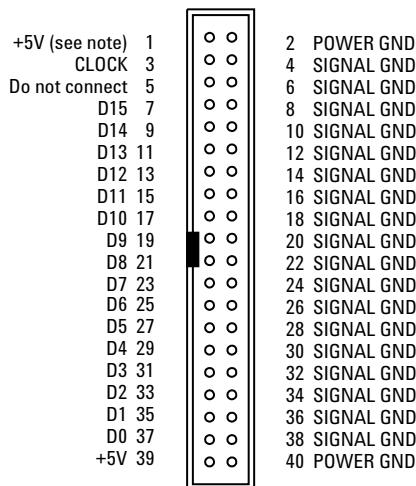


Figure 21. Forty-pin connector pinout

Note: +5V is supplied from the logic analyzer to provide power for analysis probes and demo boards. **DO NOT connect these pins to a +5V supply in the target system!**

Designing and Probing with Target Connections

For All Agilent Logic Analyzers with 40-pin Pod Connectors

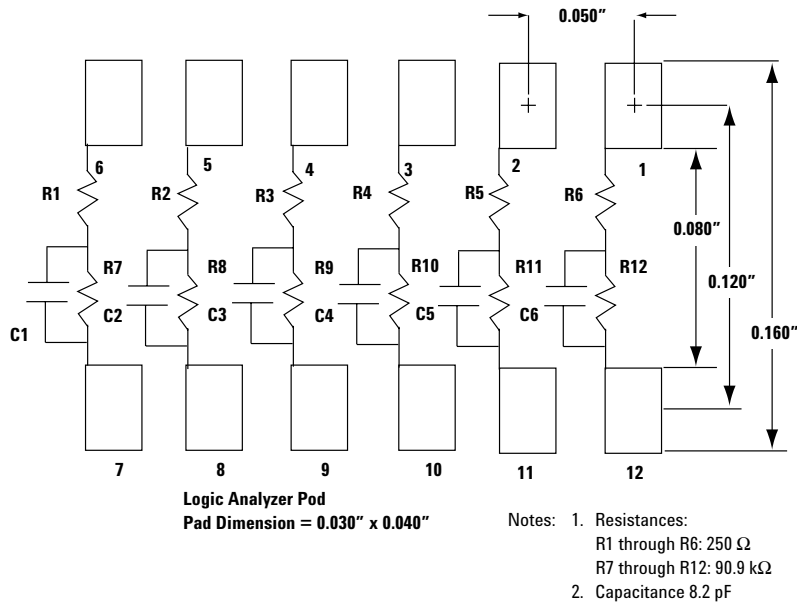


Figure 22. Recommended PC board pattern for 5062-7396 surface mount isolation network

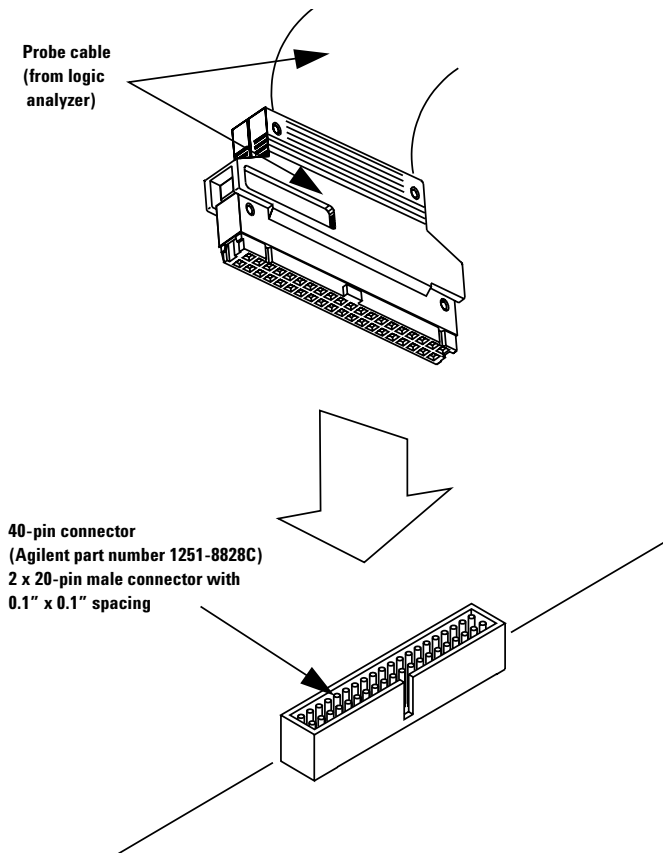


Figure 23. Connecting probe cable to 40-pin connector with isolation networks

Designing and Probing with Target Connections

For All Agilent Logic Analyzers with 40-pin Pod Connectors

Notes on Using Discrete Components

Discrete components can be used to design the isolation network. Agilent Technologies recommends the circuit shown in figure 24. To achieve the equivalent load shown in the figure, trace lengths should be minimized by locating the RC network very near the measured node. Actual load will be the stub length load added to the equivalent load in the figure. Trace length from the suggested on-board RC network to the target connector must be 3 to 4 inches or less. This transmission line should be designed for an impedance in the range of 80 to 100 ohms (closer to 100 ohms is better).

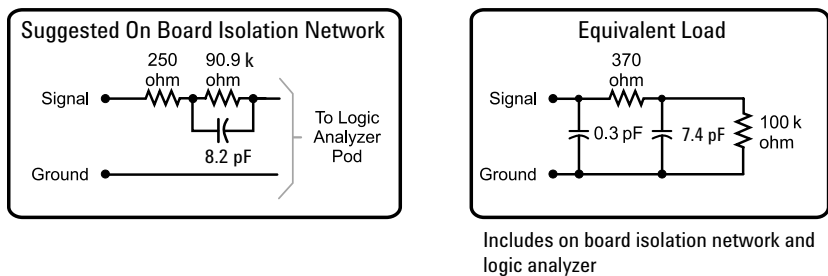


Figure 24. Equivalent load for on-target discrete components. Also applies to SMT (5062-7396) RC networks.

Designing and Probing with Target Connections

For All Agilent Logic Analyzers with 40-pin Pod Connectors

High Density, High Performance

Agilent Technologies has developed high-density probing solutions based on the 100-pin Samtec and AMP Mictor 38-pin connectors. The Agilent probes and adapter cables, E5346A, E5339A, E5351A, and E5385A provide a connection strategy to route your important signals to the Agilent logic analyzer. Simply design the connectors onto the

board for the critical signals such as address, data, and status bits. The connectors consume a minimal amount of board space. Each connector provides 32 channels of logic analysis per connector with two clocks. Connectors can be purchased directly from AMP, Samtec, or Agilent Technologies. See the “Related Information” at the end of this document.

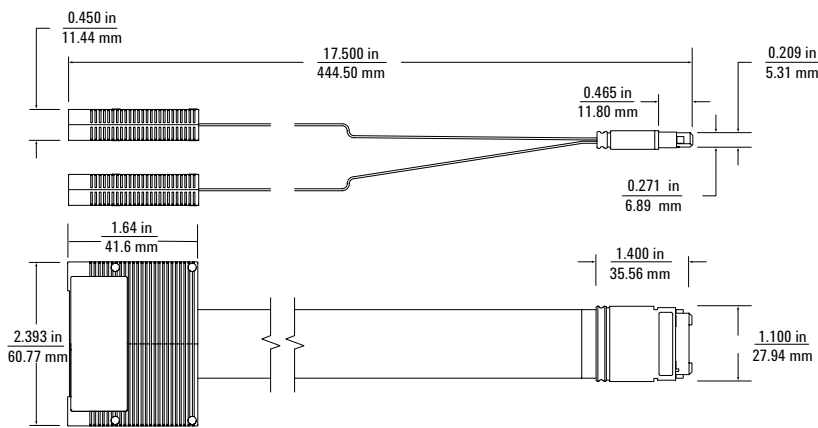


Figure 25. E5346A, E5351A, E5339A mechanical dimensions

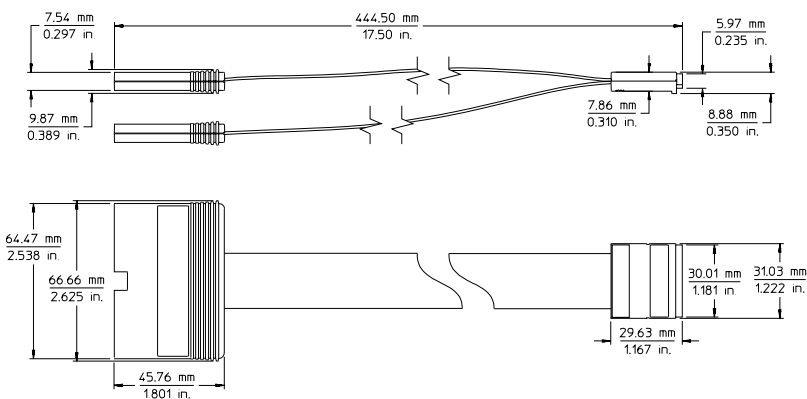


Figure 26. E5385A 100-pin probe mechanical dimensions

Designing and Probing with Target Connections

For All Agilent Logic Analyzers with 40-pin Pod Connectors

Agilent Technologies E5346A, E5339A, and E5385A Probes

The E5346A, E5339A, and E5385A probes include the required isolation networks for the logic analyzer right at the probe tip, close to the target. The E5346A and E5385A are designed to acquire signals with peak-to-peak amplitude as low as 500 mV. The E5339A is designed to acquire signals as small as 250 mV peak-to-peak. Figure 27 shows the equivalent load for the E5339A, and figure 28 shows the equivalent load for the E5346A. Figure 29 shows the equivalent load for the E5385A.

To use the E5346A, E5339A, or E5385A at high clock speeds, the following design guidelines should be observed:

- Calculate the electrical length of the probe hookup stub.
- For PC board material with $E_r=4.9$, use a propagation delay of 160 ps/inch.
- Check that the propagation delay of the probe hookup stub is less than 20% of the bus signal risetime (T_r). If it is, the E5346A, E5339A, or E5385A can be used for connection.

For example, if $E_r=4.9$, a 2.5 inch probe hookup stub generates a propagation delay of 400 ps. If T_r is > 2 ns, the E5346A, E5339A, or E5385A is a viable probing choice.

The E5346A and E5339A use the AMP Mictor 38-pin connector. The E5385A uses a 100-pin connector manufactured by Samtec. Agilent recommends the E5385A for new applications, due to the reduced input capacitive loading and improved isolation between adjacent channels.

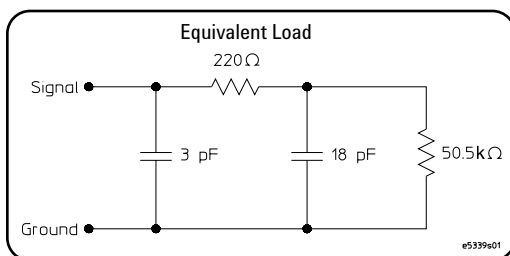


Figure 27. E5339A input equivalent load

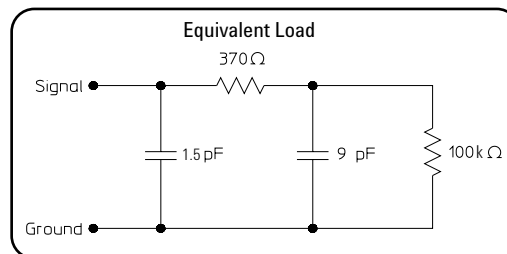


Figure 29. E5385A input equivalent load

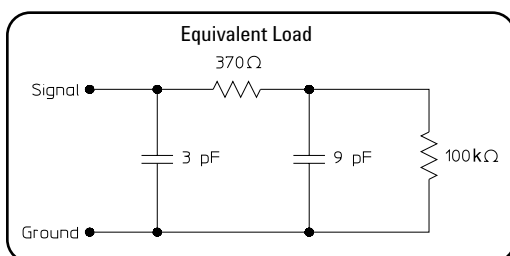


Figure 28. E5346A input equivalent load

For additional information on designing connectors into a target system, refer to the following documents:

Agilent Technologies E5346A/E5351A Probe/Adapter Cable	Installation Note	E5346-92014	http://literature.agilent.com/litweb/pdf/E5346-92014.pdf
Agilent Technologies E5339A Low Voltage Probe	Installation Note	E5339-92002	http://literature.agilent.com/litweb/pdf/E5339-92002.pdf
Agilent Technologies E5385A Probe	Installation Note	E5385-92001	http://literature.agilent.com/litweb/pdf/E5385-92001.pdf

Designing and Probing with Target Connections

For All Agilent Logic Analyzers with 40-pin Pod Connectors

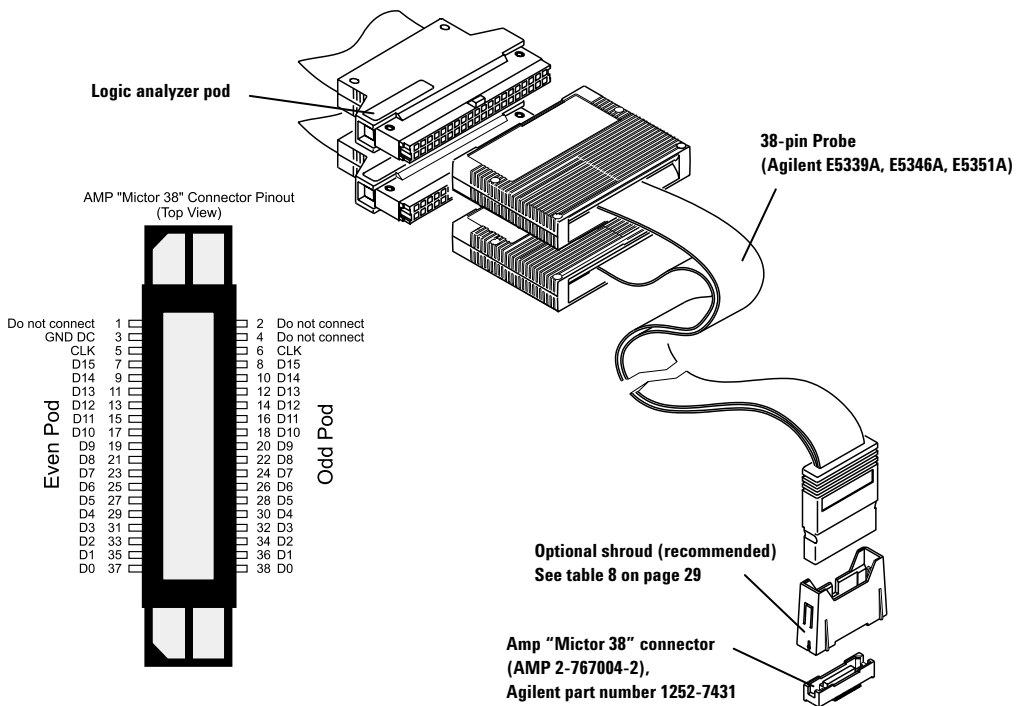


Figure 30. Agilent E5339A, E5346A, and E5351A connection and pinout

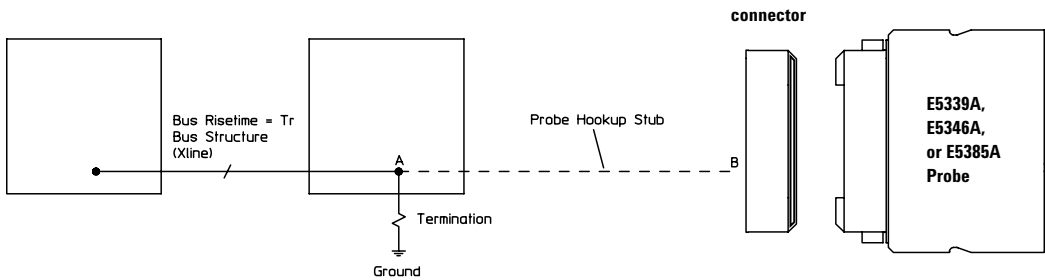


Figure 31. Agilent E5339A, E5346A, and E5385A design rules

Designing and Probing with Target Connections

For All Agilent Logic Analyzers with 40-pin Pod Connectors

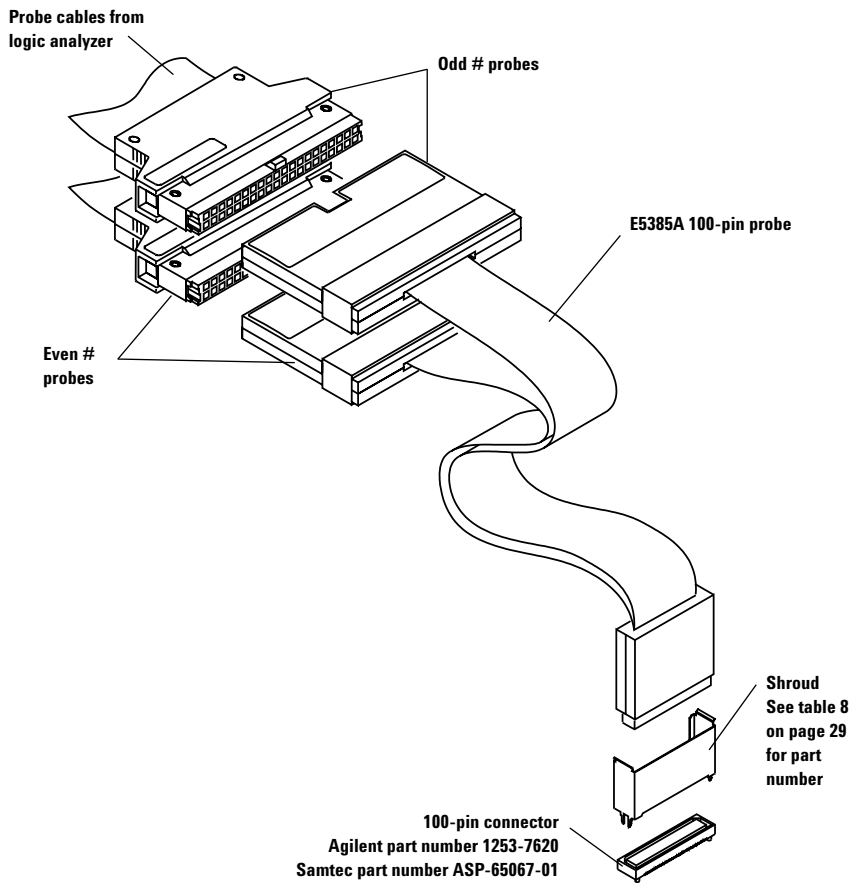


Figure 32. Agilent E5385A connection and pinout

E5385A 100-Pin Probe Pin Assignments

Signal	Pin Number	Signal	
Ground	1	2	Ground
Do Not Connect	3	4	Do Not Connect
Ground	5	6	Ground
Odd D0	7	8	Even D0
Ground	9	10	Ground
Odd D1	11	12	Even D1
Ground	13	14	Ground
Odd D2	15	16	Even D2
Ground	17	18	Ground
Odd D3	19	20	Even D3
Ground	21	22	Ground
Odd D4	23	24	Even D4
Ground	25	26	Ground
Odd D5	27	28	Even D5
Ground	29	30	Ground
Odd D6	31	32	Even D6
Ground	33	34	Ground
Odd D7	35	36	Even D7
Ground	37	38	Ground
Odd D8	39	40	Even D8
Ground	41	42	Ground
Odd D9	43	44	Even D9
Ground	45	46	Ground
Odd D10	47	48	Even D10
Ground	49	50	Ground
Odd D11	51	52	Even D11
Ground	53	54	Ground
Odd D12	55	56	Even D12
Ground	57	58	Ground
Odd D13	59	60	Even D13
Ground	61	62	Ground
Odd D14	63	64	Even D14
Ground	65	66	Ground
Odd D15	67	68	Even D15
Ground	69	70	Ground
NC	71	72	NC
Ground	73	74	Ground
NC	75	76	NC
Ground	77	78	Ground
Odd D16P/ Odd CLK	79	80	Even D16P/ Even CLK
Ground	81	82	Ground
NC	83	84	NC
Ground	85	86	Ground
NC	87	88	NC
Ground	89	90	Ground
NC	91	92	NC
Ground	93	94	Ground
Ground	95	96	Ground
+5v	97	98	+5v
+5v	99	100	+5v

Designing and Probing with Target Connections

For All Agilent Logic Analyzers with 40-pin Pod Connectors

Agilent Technologies E5351A 38-Pin Adapter Cable

If the calculated electrical length of the required routing stub prohibits the use of the Agilent E5339A, E5346A, or E5385A, the Agilent E5351A can be used with the required isolation networks installed on the target.

The E5351A does not have its own internal isolation networks. When using the E5351A, place the SIP isolation networks, surface mount isolation network 5062-7396, or equivalent discrete components very near the target component for measurement.

Ensure that the stub length between the target component and the isolation network is short. The stub propagation delay should be less than 20% of the bus signal rise time, as mentioned before. The transmission line from the on-board isolation network to the Mictor connector should be designed for an impedance in the range of 80 to 100 ohms (closer to 100 ohms is better). This length should not exceed 3 to 4 inches, and all signal line lengths should be equal. Signal line length variation should not cause propagation delay variation to exceed 20 ps between signal lines.

Notes on Using Discrete Components

Discrete components can be used in the design of the RC network. Agilent Technologies recommends the circuit shown in figure 24. To achieve the equivalent load shown in the figure, trace lengths should be minimized by locating the RC network very near the measured node. Actual load will be the stub length load added to the equivalent load in the figure.

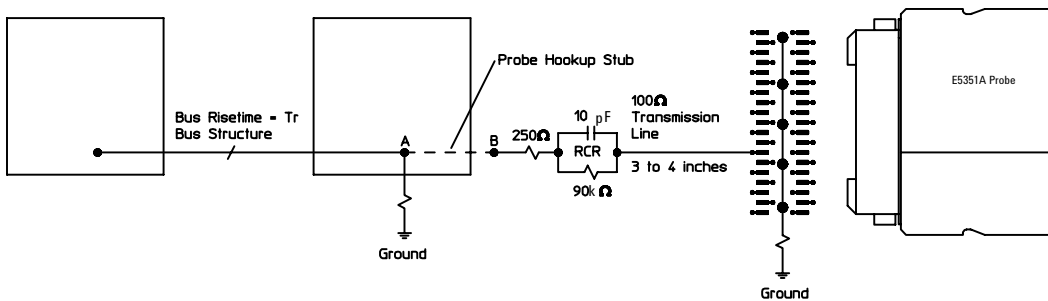


Figure 33. Agilent Technologies E5351A design rules

Designing and Probing with Target Connections

For All Agilent Logic Analyzers with 40-pin Pod Connectors

Options for On-Board Terminations for the E5351A

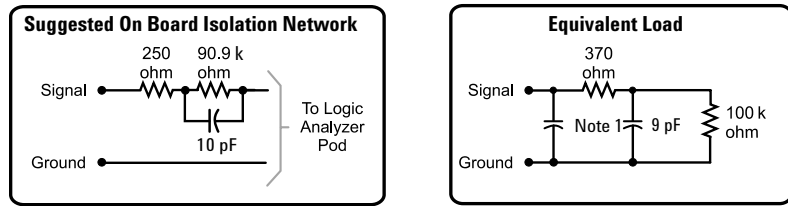
There are two options for isolating the E5351A on the target PC board:

- Use the surface mount isolation network, Agilent part number 5062-7396. Refer to figure 35 for schematic and pinout.
- Use discrete components. Refer to figure 34 for recommended components and equivalent load.

If you are operating at state speeds above 200 MHz, you should use discrete components for best results. Due to the added electrical length of the E5351A probe cable, the divider compensating capacitors in the SIP, and surface-mount isolation networks are not optimum for the E5351A, but they are usable up to 200 MHz clock rates.

Notes on Using the 5062-7396 SMT Part

Agilent currently recommends a two-step process in soldering the SMT part to the board. The first pass places solder paste on those pads with vias. Application of heat allows the via to fill with solder. (If only one solder step is used, the solder wicks away from the part into the via and a solid connection will not be made with the part.) The next pass places solder paste on all of the pads.



Includes on board RC network and logic analyzer

Figure 34. Suggested on-board isolation network and equivalent load when using discrete components to terminate the E5351A

Note 1: The effective input capacitance for on-board isolation networks is purely a function of geometry - 0.3 pF is about as low as can be achieved.
 Note 2: The equivalent load is the same when using the surface-mount isolation network, 5062-7396.

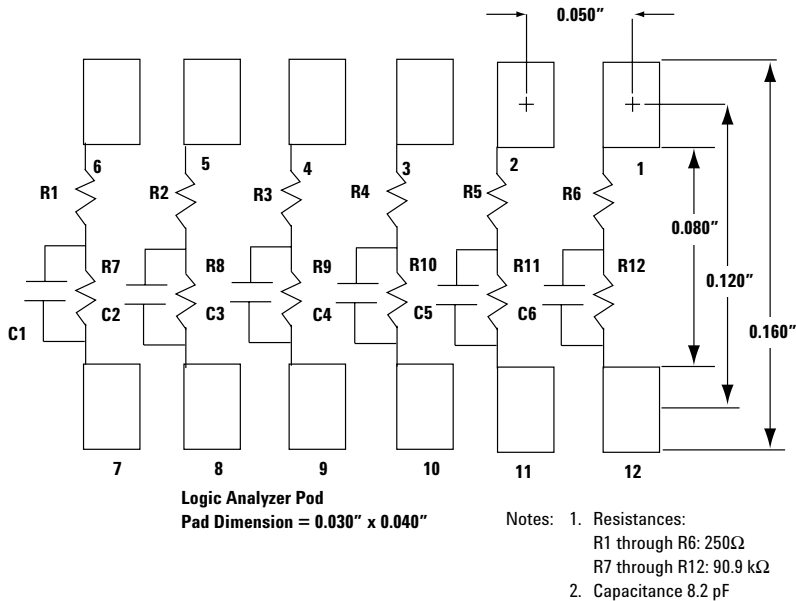


Figure 35. Recommended PC board pattern for 5062-7396 surface mount isolation network

As shown in figure 35, the 5062-7396 SMT isolation network supports six logic analysis channels. The size of the part allows you to repeat the pattern in figure 35 to accommodate multiple parts stacked end-to-end for the number of channels needed in your application. Three of these SMTs are required for each probe

cable. The process for using the ceramic hybrid isolation network is similar to the process for an LCC package. Due to the small part size, thermal expansion mismatch during solder reflow should not be a problem. Capacitance also remains stable with temperature changes.

Designing and Probing with Target Connections

For All Agilent Logic Analyzers with 40-pin Pod Connectors

Support Shrouds

A support shroud is recommended to provide additional strain relief between the probe and the connector, as shown in figures 30 and 32. Two plated through-holes are required on the target board. The shroud is mounted directly to the target board using the through-holes. This places the shroud around the connector, providing solid mechanical strain relief. Connector kits are available; table 8 shows the Agilent part numbers for shrouds and connector kits for various PC board thicknesses.

For probe model numbers	Description	Agilent part number
E5339A, E5346A, E5351A	Kit of 5 support shrouds and 5 38-pin Mictor connectors for PC board thickness up to 1.57 mm (0.062")	E5346-68701
	Kit of 5 support shrouds and 5 38-pin Mictor connectors for PC board thickness up to 3.175 mm (0.125")	E5346-68700
	One 38-pin Mictor connector (also available from AMP as part number 2-767004-2)	1252-7431
	One support shroud for PC board thickness up to 1.57 mm (0.062")	E5346-44701
	One support shroud for PC board thickness up to 3.175 mm (0.125")	E5346-44704
	One support shroud for PC board thickness up to 4.318 mm (0.700")	E5346-44703
E5385A	Kit of 5 support shrouds and 5 100-pin Samtec connectors for PC board thickness up to 1.57 mm (0.062")	16760-68702
	Kit of 5 support shrouds and 5 100-pin Samtec connectors for PC board thickness up to 3.05 mm (0.120")	16760-68703
	One 100-pin Samtec connector (also available from Samtec as part number ASP-65067-01)	1253-3620
	One support shroud for PC board thickness up to 1.57 mm (0.062")	16760-02302
	One support shroud for PC board thickness up to 3.05 mm (0.120")	16760-02303

Table 8. Mating connectors, shrouds, and kits for Agilent E5339A, E5346A, E5351A, and E5385A probes

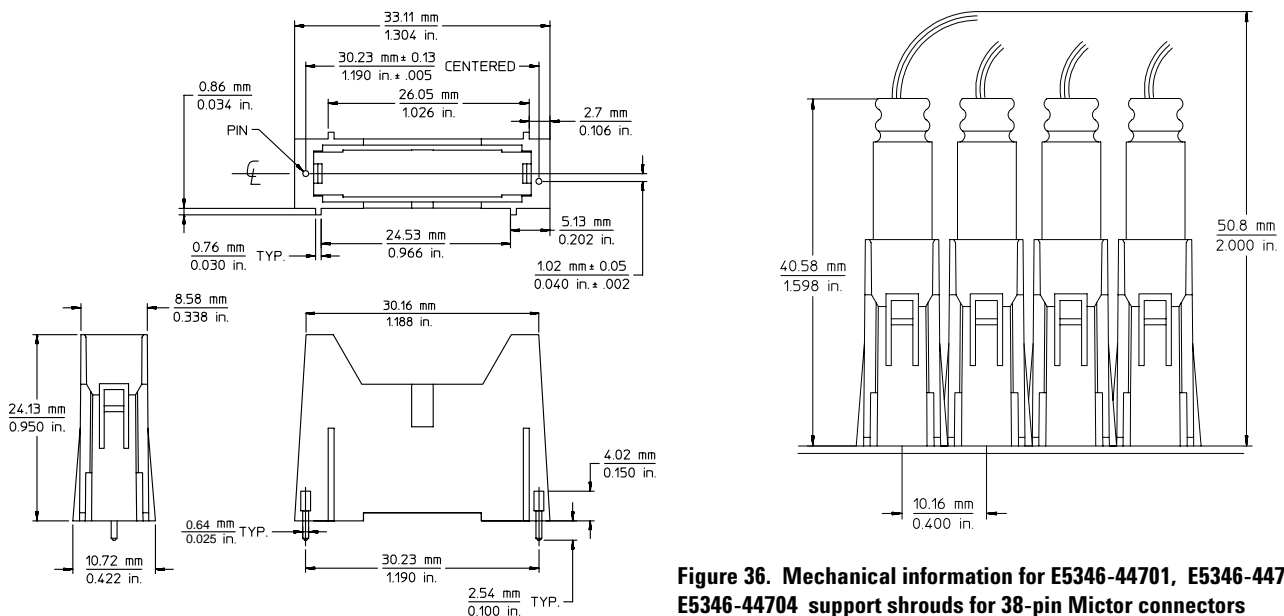


Figure 36. Mechanical information for E5346-44701, E5346-44703, E5346-44704 support shrouds for 38-pin Mictor connectors

Designing and Probing with Target Connections

Probing Individual Pins of High-Density Connectors

38-pin Mictor Adapter

Signals routed out to AMP Mictor connectors can also be accessed by other test equipment, such as an oscilloscope.

The E5346-60002 plugs directly into the Mictor connector and brings all 32 signals out to standard connector pins through flex circuits, as shown in figure 37.

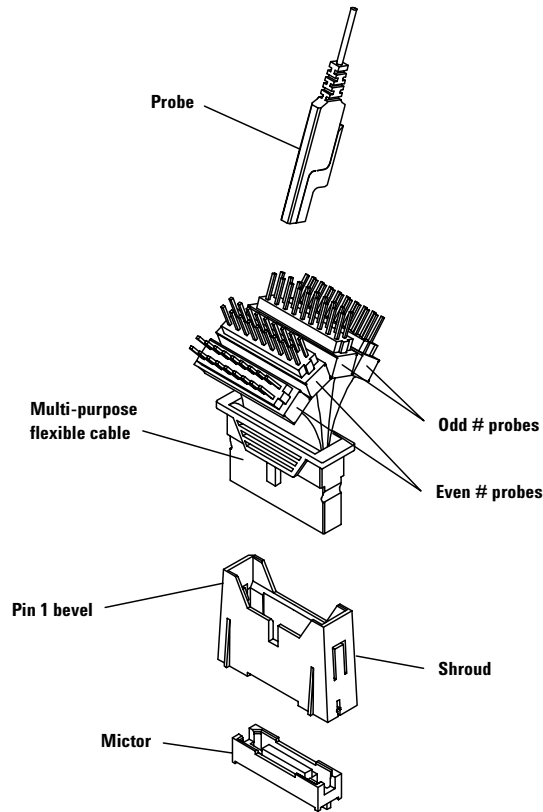


Figure 37. E5346-60002 Mictor break-out adapter

Designing and Probing with Target Connections

Right-Angle Mictor Adapter

For systems with space constraints above the 38-pin connector, Agilent Technologies offers a right-angle adapter, as shown in figure 38. With the E5346-63201 right-angle adapter inserted in the 38-pin connector, the adapter cable is connected parallel to the target board surface. When using the right-angle adapters, the 38-pin connectors must be placed end-to-end on the target board, as shown in figure 39. Support shrouds cannot be used with the right-angle adapter.

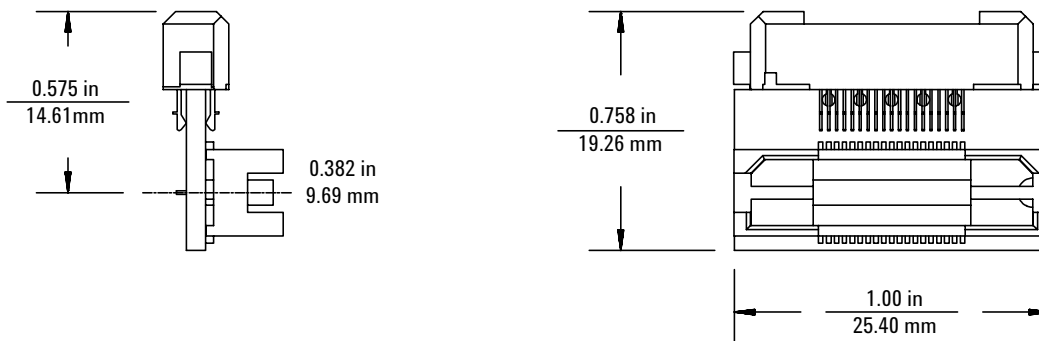
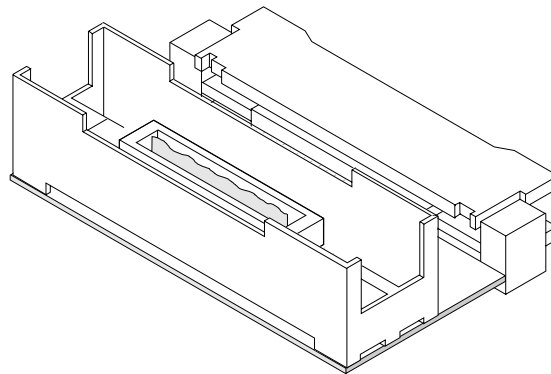


Figure 38. E5346-63201 right-angle 38-pin adapter

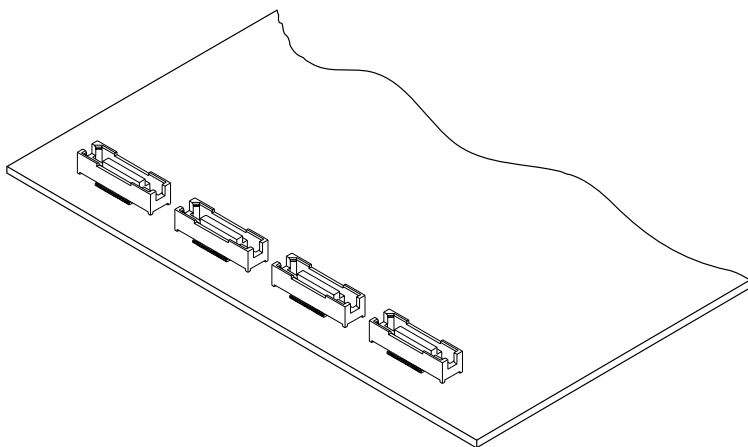


Figure 39. 38-pin connectors placed for use of right-angle adapter

Note: the right-angle adapter adds significant capacitance and inductance in series with the probe. It is not recommended for state speeds above 100 MHz or for signals with rise times < 4 - 5 ns.

Designing and Probing with Target Connections

Agilent Logic Analyzers with 90-pin Pod Connectors

Five options are available for connecting the Agilent logic analyzers with 90-pin pod connectors to a target system using mass connections.

Agilent soft-touch connectorless probes

Agilent's soft-touch connectorless probes use spring-loaded pin technology to provide reliable contact which is not dependent on the planarity of the PC board or the plating processes used to fabricate the board. No special cleaning processes are required when using Agilent's soft-touch probes.

Refer to figures 40 through 43 on pages 32 and 33 for dimensional drawings, board contact dimensions, and load models for soft touch probes.

The E5387A is a 17-channel differential probe capable of acquiring data up to 1.5 Gb/s (when used with the Agilent 16760A). The probe has the following inputs:

- 16 differential data inputs
- 1 differential clock input.

The clock input can be used as a data input if not used as a clock or qualifier.

E5390A soft touch single-ended probe (available first quarter 2003)

The E5390A is a 34-channel single-ended probe capable of acquiring data up to 1.5 Gb/s (when used with the Agilent 16760A). The probe has the following inputs:

- 34 single-ended data inputs
- 2 differential clock inputs.
- 2 data reference threshold inputs

The clock inputs can be used as data inputs if not used as a clock or qualifier.

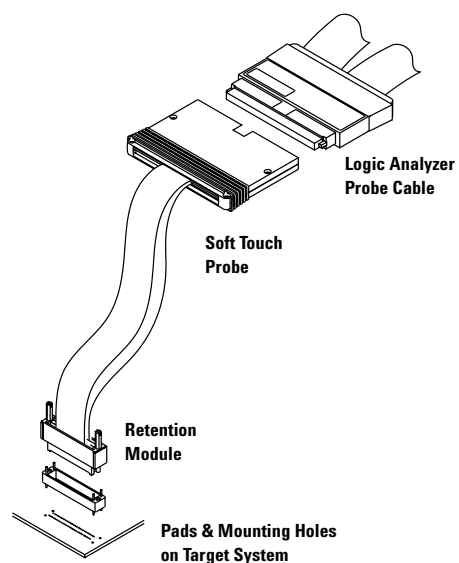


Figure 40. E5387A soft touch differential probe

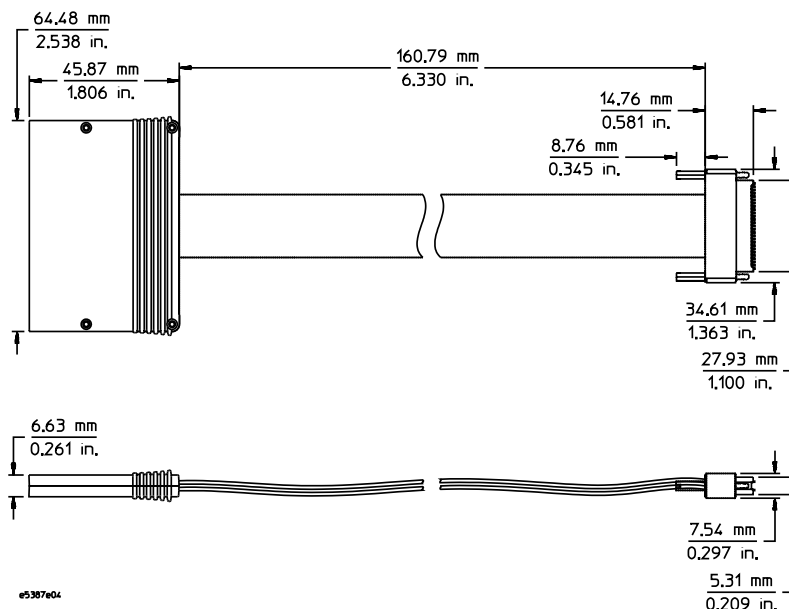


Figure 41. Soft touch probe (E5387A and E5390A) dimensions

Designing and Probing with Target Connections

Agilent Logic Analyzers with 90-pin Pod Connectors

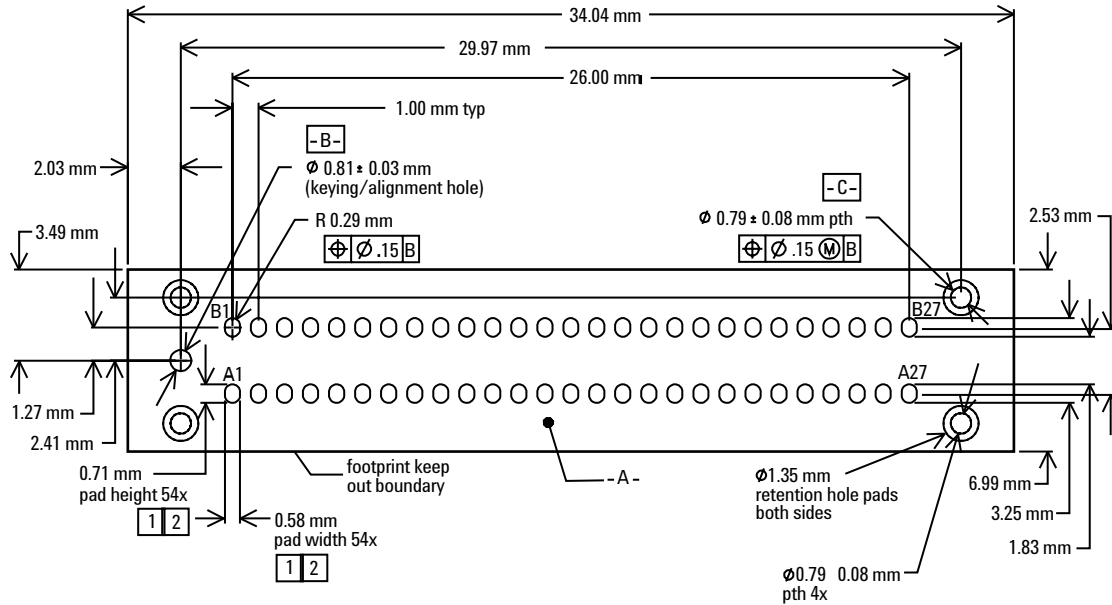


Figure 42. Soft touch probe (E5387A and E5390A) probe PC board layout dimensions

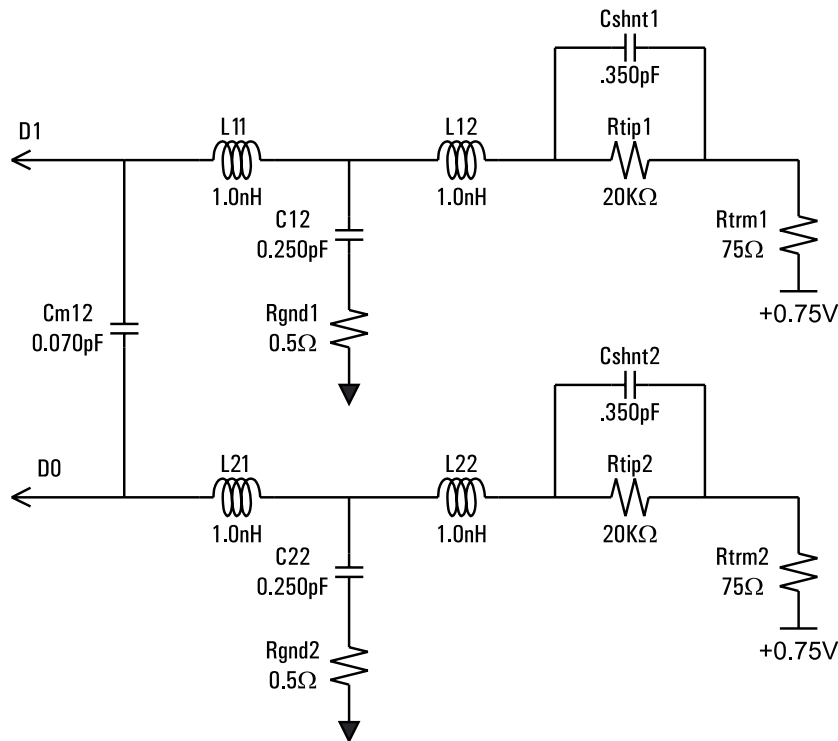


Figure 43. Load model for soft touch probes

Agilent soft touch probes require a retention module mounted to the target printed circuit board. A kit of 5 retention modules is shipped with each soft touch probe. Additional kits can be ordered, Agilent part number E5387-68701.

Designing and Probing with Target Connections

Agilent Logic Analyzers with 90-pin Pod Connectors

E5390A Single-ended Soft Touch Probe Pin-out

PAD#	Pod Input	PAD#	Pod Input
A1	Odd D1	B1	Odd D0
A2	Odd D3	B2	Odd D2
A3	Ground	B3	Ground
A4	Odd D5	B4	Odd D4
A5	Odd D7	B5	Odd D6
A6	Ground	B6	Ground
A7	Odd D9	B7	Odd D8
A8	Odd D11	B8	Odd D10
A8	Ground	B9	Ground
A10	Odd D13	B10	Odd D12
A11	Odd D15	B11	Odd D14
A12	Ground	B12	Ground
A13	Odd CLKN/D16N	B13	Odd CLKP/D16P
A14	Ground	B14	Ground
A15	Even D1	B15	Even D0
A16	Even D3	B16	Even D2
A17	Ground	B17	Ground
A18	Even D5	B18	Even D4
A19	Even D7	B19	Even D6
A20	Ground	B20	Ground
A21	Even D9	B21	Even D8
A22	Even D11	B22	Even D10
A23	Ground	B23	Ground
A24	Even D13	B24	Even D12
A25	Even D15	B25	Even D14
A26	Ground	B26	Ground
A27	Even CLKN/D16N	B27	Even CLKP/D16P

Table 9. Pin assignments for single-ended soft touch probe, E5390A

Designing and Probing with Target Connections

Agilent Logic Analyzers with 90-pin Pod Connectors

E5387A Differential Soft Touch Probe Pin-out

PAD#	Pod Input	PAD#	Pod Input
A1	nD0 (-)	B1	D0 (+)
A2	nD1 (-)	B2	D1 (+)
A3	Ground	B3	Ground
A4	nD2 (-)	B4	D2 (+)
A5	nD3 (-)	B5	D3 (+)
A6	Ground	B6	Ground
A7	nd4 (-)	B7	D4 (+)
A8	nD5 (-)	B8	D5 (+)
A8	Ground	B9	Ground
A10	nD6 (-)	B10	D6 (+)
A11	nD7 (-)	B11	D7 (+)
A12	Ground	B12	Ground
A13	nCLOCK (-)	B13	CLOCK (+)
A14	Ground	B14	Ground
A15	nD8 (-)	B15	D8 (+)
A16	nD9 (-)	B16	D9 (+)
A17	Ground	B17	Ground
A18	nD10 (-)	B18	D10 (+)
A19	nD11 (-)	B19	D11 (+)
A20	Ground	B20	Ground
A21	nD12 (-)	B21	D12 (+)
A22	nD13 (-)	B22	D13 (+)
A23	Ground	B23	Ground
A24	nD14 (-)	B24	D14 (+)
A25	nD15 (-)	B25	D15 (+)
A26	Ground	B26	Ground
A27	N/C	B27	N/C

Table 10. Pin assignments for differential soft touch probe, E5387A

Designing and Probing with Target Connections

Agilent Logic Analyzers with 90-pin Pod Connectors

E5378A 100-Pin Single-Ended Probe

The E5378A is a 34-channel single-ended probe capable of capturing data up to 1.5 Gbits/sec (see figures 51 and 53 for probe dimensions and equivalent load). The probe has the following inputs:

- 32 single-ended data inputs, in two groups (pods) of 16.
- Two differential clock inputs. Either or both clock inputs can be acquired as data inputs if not used as a clock.
- Two data threshold reference inputs, one for each pod (group of 16 data inputs).

E5379A 100-Pin Differential Probe

The E5379A is a 17-channel differential probe capable of capturing data up to 1.5 Gbits/sec (see figures 52 and 53 for probe dimensions and equivalent load). The probe has the following inputs:

- 16 differential data inputs.
- One differential clock input. The clock input can be acquired as a data input if it is not used as a clock.

Refer to table 11 on page 38 for part numbers for mating connectors and shrouds.

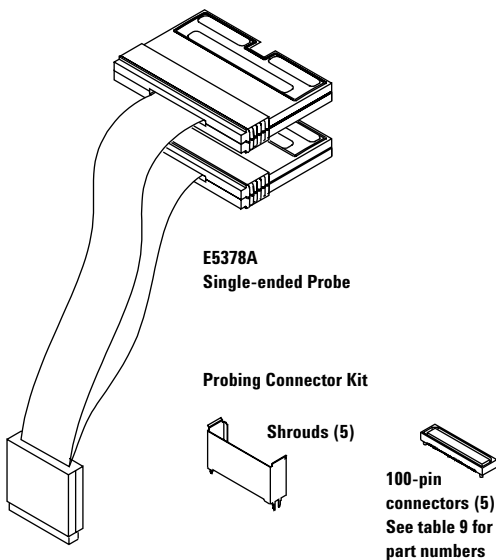


Figure 44. Agilent E5378A probe

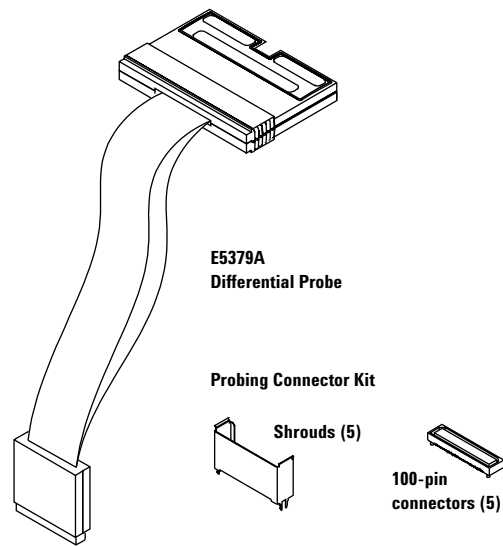


Figure 45. Agilent E5379A probe

Designing and Probing with Target Connections

Agilent 16760A 1.5 Gbits/Sec Logic Analyzer Module

E5386A Half-Channel Adapter

When the Agilent 16760A is operated in the 1250 Mb/s or 1500 Mb/s mode, only the even numbered channels are used. To reduce the number of probes and connectors required, the E5386A adapter maps the even channels to all of the pins of an E5378A, E5379A, E5387A, or E5390A probe. The E5386A half-channel adapter is usable with either the E5378A or E5387A single-ended probe or the E5379A or E5390A differential probe. The following diagrams show how the E5386A is connected.



Figure 46. E5386A half-channel probe adapter.

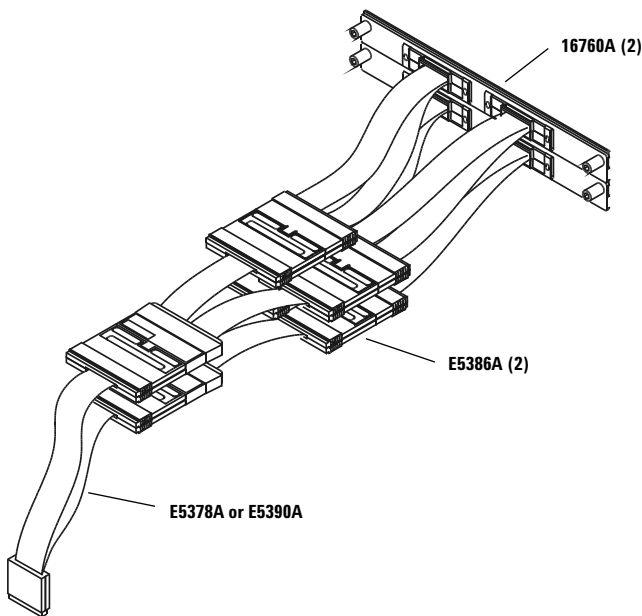


Figure 47. E5386A with E5378A or E5390A single-ended probe.

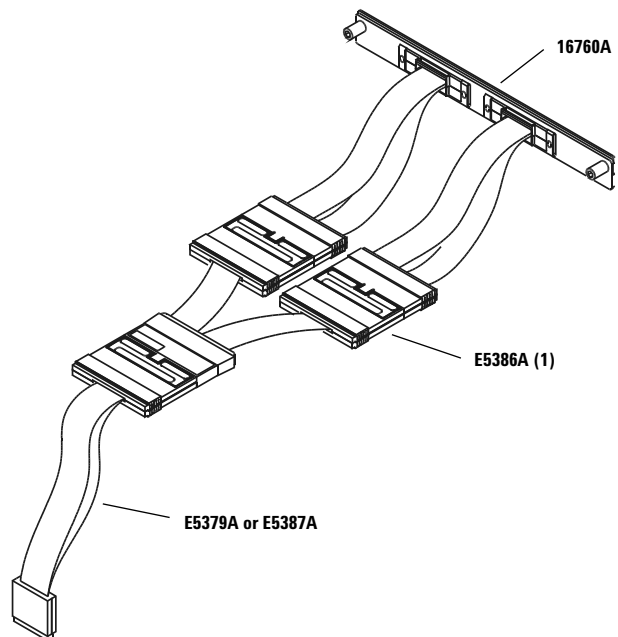


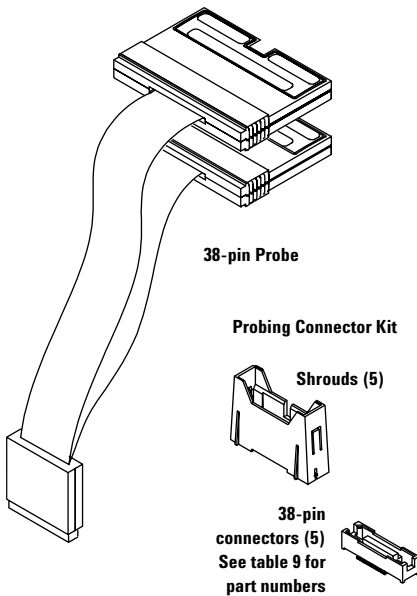
Figure 48. E5386A with E5379A or E5387A differential probe.

Designing and Probing with Target Connections

Agilent Logic Analyzers with 90-pin Pod Connectors

E5380A 38-Pin Probe

The E5380A is designed to be compatible with the Agilent E5346A high-density probe adapter and the Mictor connector. If you have a target system designed for connection to the E5346A high-density probe adapter, the E5380A probe will connect directly to this same Mictor connector. (For information on the E5346A, refer to pages 23-24). The maximum state speed when used with the E5380A probe is 600 Mb/s. The minimum input signal amplitude required by the E5380A is 300 mV.



The E5380A probe combines two 17-channel cables into a single-ended 38-pin Mictor connector.

Refer to table 11 for connector, shroud, and kit part numbers.

For probe model numbers	Description	Agilent part number
E5378A, E5379A	Kit of 5 support shrouds and 5 100-pin Samtec connectors for PC board thickness up to 1.57 mm (0.062")	16760-68702
	Kit of 5 support shrouds and 5 100-pin Samtec connectors for PC board thickness up to 3.05 mm (0.120")	16760-68703
	One 100-pin Samtec connector (also available from Samtec as part number ASP-65067-01)	1253-3620
	One support shroud for PC board thickness up to 1.57 mm (0.062")	16760-02302
	One support shroud for PC board thickness up to 3.05 mm (0.120")	16760-02303
E5380A	Kit of 5 support shrouds and 5 38-pin Mictor connectors for PC board thickness up to 1.57 mm (0.062")	E5346-68701
	Kit of 5 support shrouds and 5 38-pin Mictor connectors for PC board thickness up to 3.175 mm (0.125")	E5346-68700
	One 38-pin Mictor connector (also available from AMP as part number 2-767004-2)	1252-7431
	One support shroud for PC board thickness up to 1.57 mm (0.062")	E5346-44701
	One support shroud for PC board thickness up to 3.175 mm (0.125")	E4346-44704
	One support shroud for PC board thickness up to 4.318 mm (0.700")	E5346-44703

Table 11. Mating connectors, shrouds, and kits for Agilent E5378A, E5379A, and E5380A probes

Figure 49. Agilent E5380A probe

For further information on designing the E5378A, E5379A, or E5380A probe connectors into your system, refer to the following documents:

Agilent Technologies Logic Analyzer Probes (E5378A, E5379A, E5380A, and E5386A) User's Guide	Mechanical drawings, electrical models, general information on probes for logic analyzers with 90-pin connectors	16760-97008	http://cp.literature.agilent.com/litweb/pdf/16760-97008.pdf
Designing High-Speed Digital Systems for Logic Analyzer Probing	Design recommendations, examples, and analysis for layout of target systems	5988-2989EN	http://www.agilent.com/find/probeguide

Designing and Probing with Target Connections

Agilent Logic Analyzers with 90-pin Pod Connectors

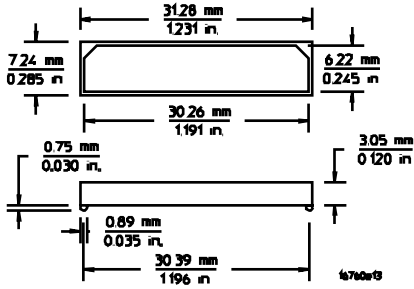


Figure 50. Dimensions of the 100-Pin Samtec connector used in the 16760-68702 and 16760-68703 connector kits

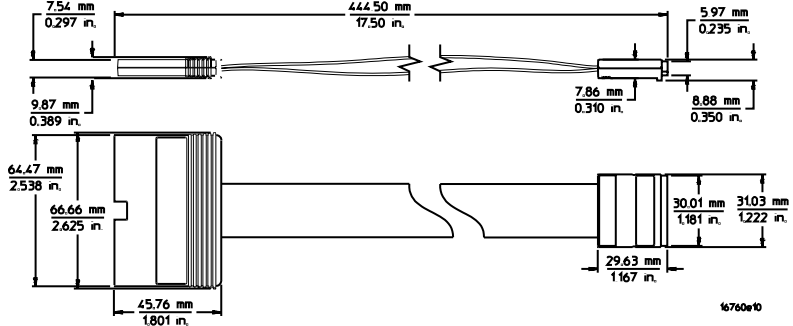


Figure 51. E5378A 100-pin single-ended probe dimensions

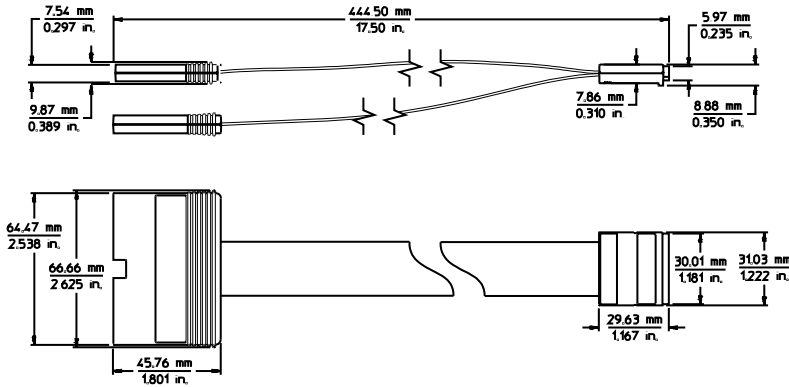


Figure 52. E5379A 100-pin differential probe dimensions

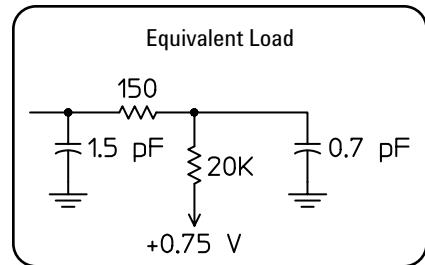


Figure 53. E5378A and E5379A input equivalent load, including 100-pin connector

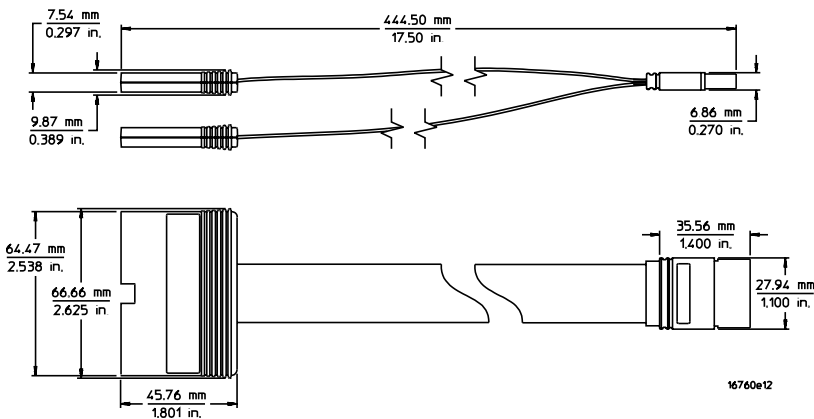


Figure 54. E5380A 38-Pin probe dimensions

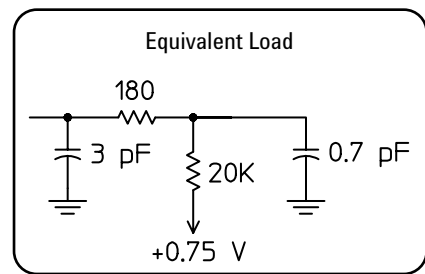


Figure 55. E5380A input equivalent load, including 38-pin connector

General-Purpose Probing

Agilent Logic Analyzers with 90-pin Pod Connectors

E5382A Single-ended Flying Lead Probe Set

The E5382A 17 channel single-ended flying lead probe set compatible with logic analyzers with a 90-pin pod connection. Accessories supplied with the flying leads are shown in table 12.


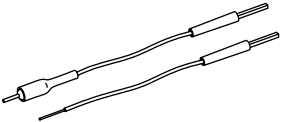
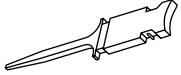

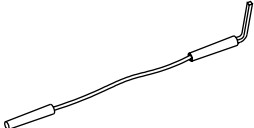
	Part number	Description
	E5382-82102	Probe pin kit, 2 resistive pins per kit
	E5382-82101	High-frequency probing kit, 2 resistive signal wires and 4 ground wires per kit
	16517-82109	Grabber clip kit, 20 grabbers per kit
	16517-82105	Ground extender kit, 20 ground extenders per kit
	16517-82106	Right-angle ground lead kit, 20 ground leads per kit

Table 12. Accessories.

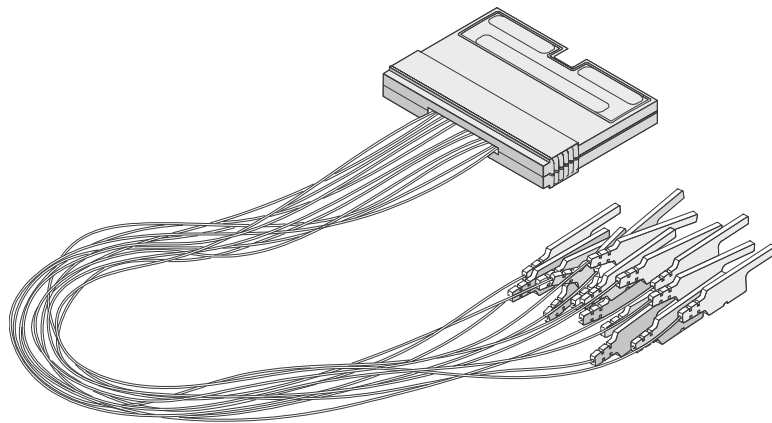


Figure 56. E5382A flying lead set

General-Purpose Probing

Agilent Logic Analyzers with 90-pin Pod Connectors

Suggested Configurations and Characteristics

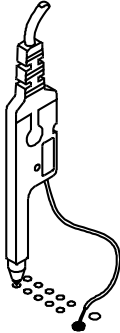
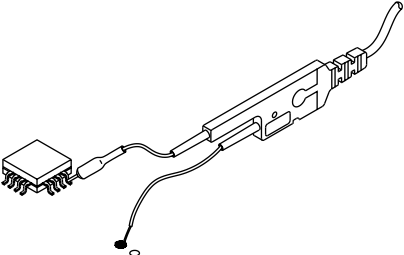
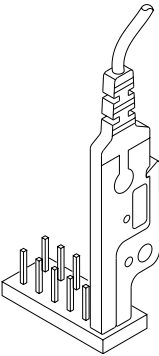
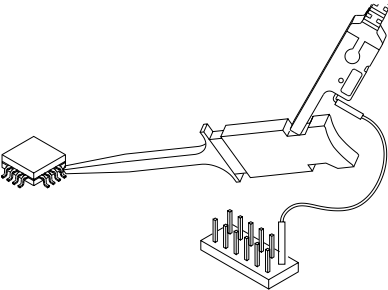
Configuration	Description	Total lumped input C	Maximum recommended state speed
	130 Ω Resistive Signal Pin (orange) and Solder-down Ground Lead	1.3 pF	1.5 Gb/s
	5 cm Resistive Signal Lead (can be Soldered-down) and Solder-down Ground Lead	1.6 pF	1.5 Gb/s
	Flying Lead and Ground Extender	1.4 pF	1.5 Gb/s
	Grabber Clip and Right-angle Ground Lead	2.0 pF	600 Mb/s

Table 13. E5382A suggested configurations and characteristics

General-Purpose Probing

Agilent Logic Analyzers with 90-pin Pod Connectors

Available Accessories

Ground connector

It is essential to ground every tip that is in use. For best performance at high speeds, every tip should be grounded individually to ground in the system under test. For convenience in connecting grounds, you can use the ground connector, Agilent part number 16515-27601, to combine up to four probe tip grounds to connect to one ground point in the system under test.

Adapting to coaxial connectors

The Agilent E9638A probe tip to BNC adapter can be used to connect one of the flying lead probes of the E5382A to a BNC connector. To probe other coaxial connectors, use the E9638A adapter, a BNC termination, and an adapter to the other type of coaxial connector. Refer to figure 58.

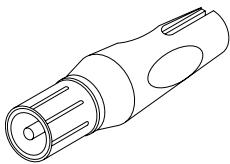


Figure 57. E9638A BNC to probe tip adapter

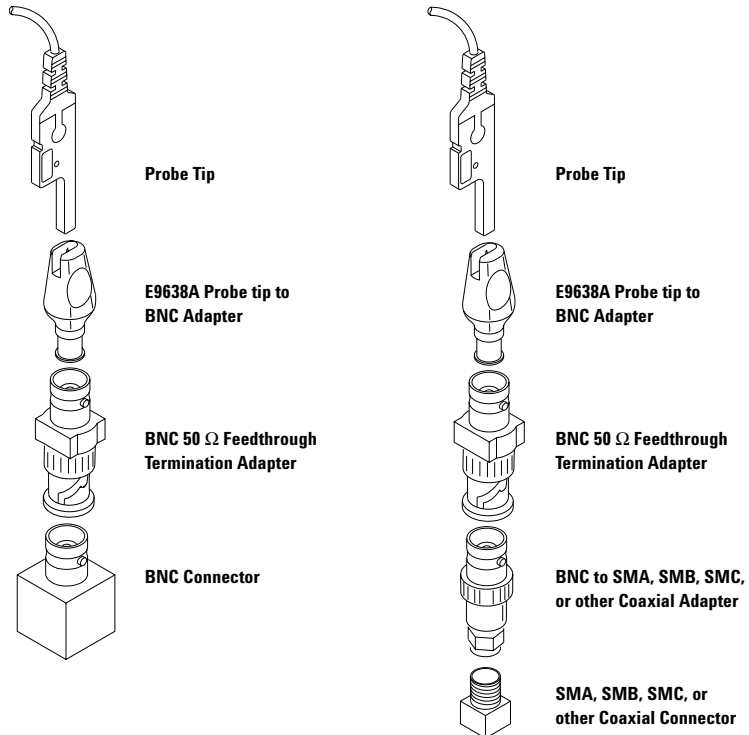
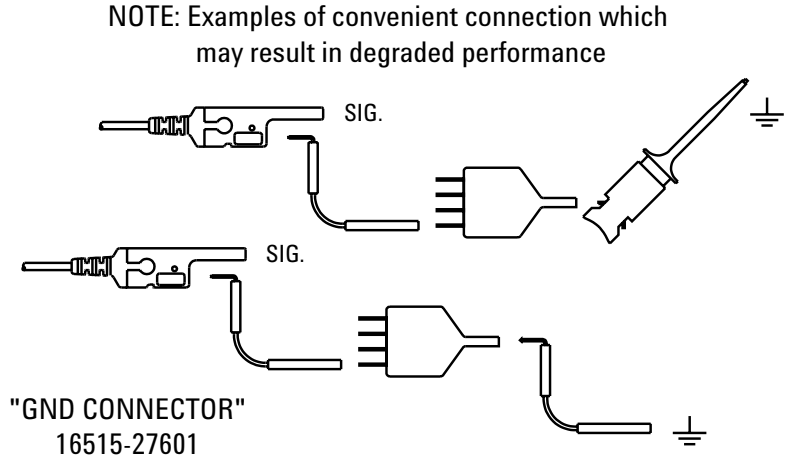


Figure 58. Recommended configurations to probe RF coaxial connectors with the E5382A flying lead probes

General-Purpose Probing

Agilent Logic Analyzers with 90-pin Pod Connectors

E5381A differential flying-lead probe set

The E5381A is a 17 channel differential flying-lead probe set, capable of probing differential or single-ended signals, compatible with logic analyzer with a 90-pin pod connection.

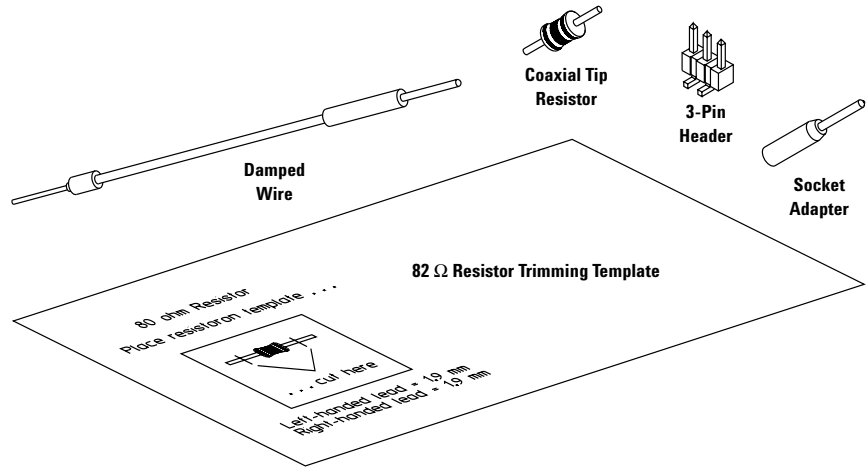


Figure 59. E5381A differential flying-lead probe set accessories

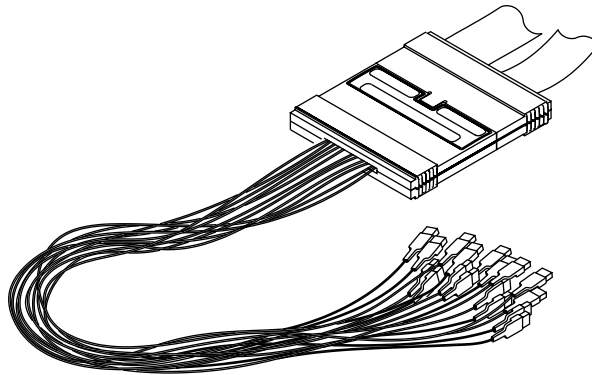


Figure 60. E5381A differential flying-lead probe set

General-Purpose Probing

Agilent Logic Analyzers with 90-pin Pod Connectors

Suggested Configurations and Characteristics

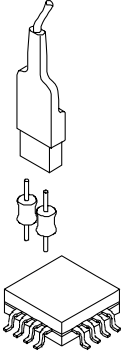
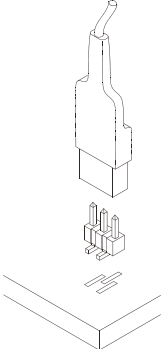
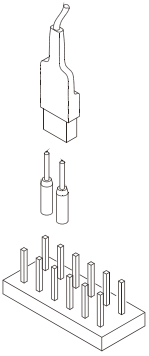
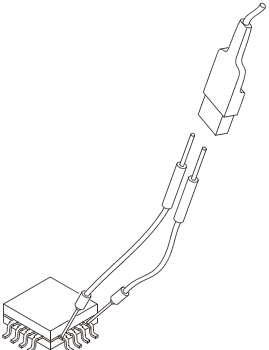
Configuration	Description	Total lumped input C	Maximum recommended state speed
	Coaxial Tip Resistor (82 Ω blue) Solder Attach to Components, Traces, Pads, or VIAs.	0.9 pF	1.5 Gb/s
	3-pin Header	1.0 pF	1.5 Gb/s
	Socket Adapter	1.1 pF	1.5 Gb/s
	Damped Wire Solder Attach to Components, Traces, Pads, or VIAs.	1.3 pF	1.5 Gb/s

Table 14. E5381A suggested configurations and characteristics

Agilent 16517A/16518A 1 GHz State / 4 GHz Timing

High-Speed Logic Analysis General-Purpose Probes

The Agilent 16517A and 16518A logic analysis modules were discontinued in April 2002. Probing accessories for these modules are listed here for convenience in ordering additional accessories if needed.

Special Connectors

The Agilent 16517A/16518A can conveniently probe an SMA or BNC connector with the adapters shown in figures 63 and 57. The flexible ground pin, figure 56, provides excellent signal fidelity when used as shown in figure 66.

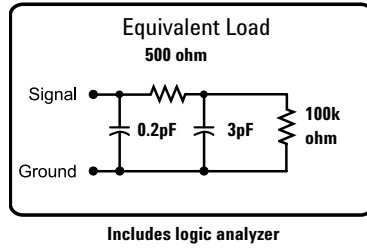


Figure 61. Equivalent load for high-speed general-purpose probe



Figure 62. E5320-26101 flexible ground pin

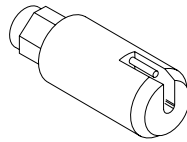


Figure 63. 16517-27601 SMA adapter

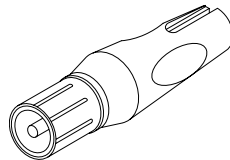


Figure 64. E9638A Probe tip to BNC adapter

Agilent 16517A/16518A 1 GHz State / 4 GHz Timing

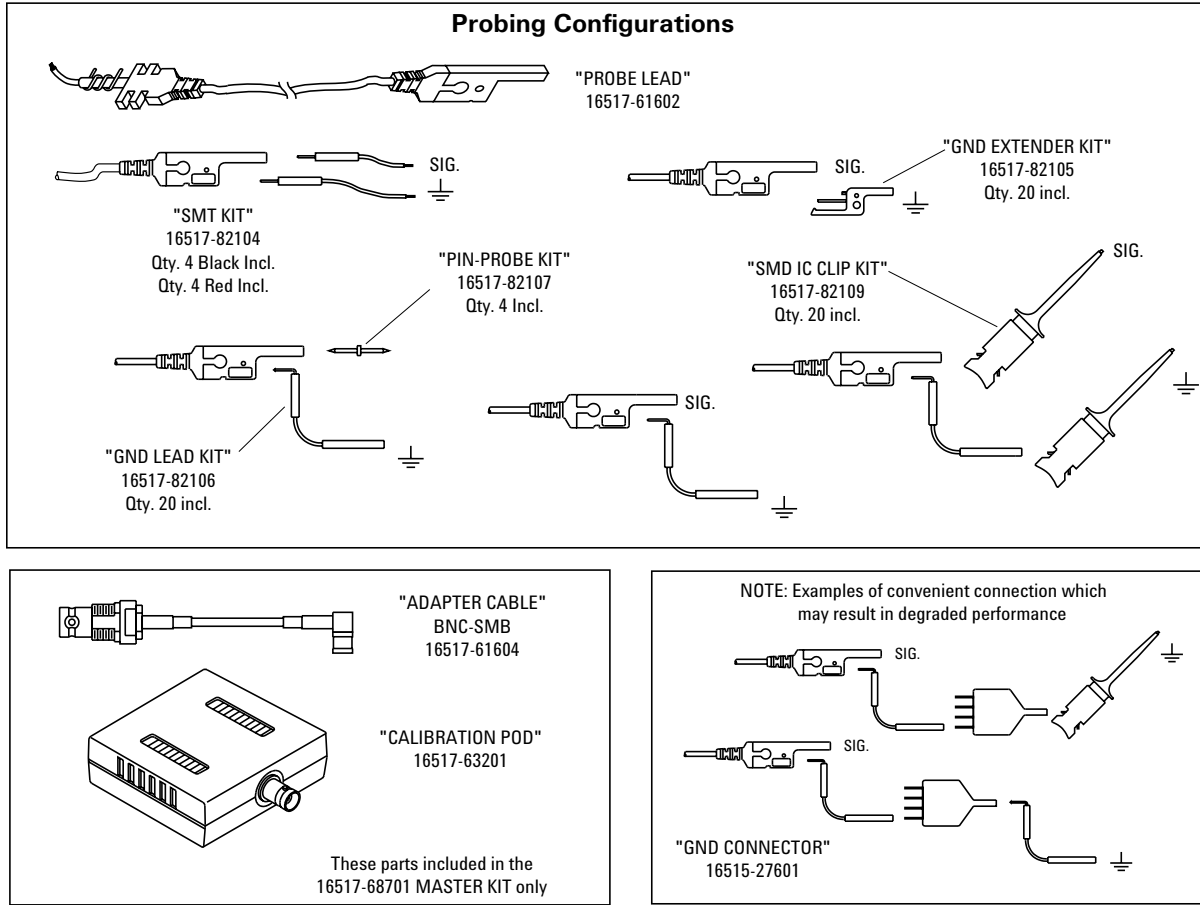


Figure 65. Agilent Technologies 16517-68701 master accessory kit and 16518-68701 expansion accessory kit

Recommended Probe Configurations

For the best performance, use the following configurations. The configurations are listed in the recommended order.

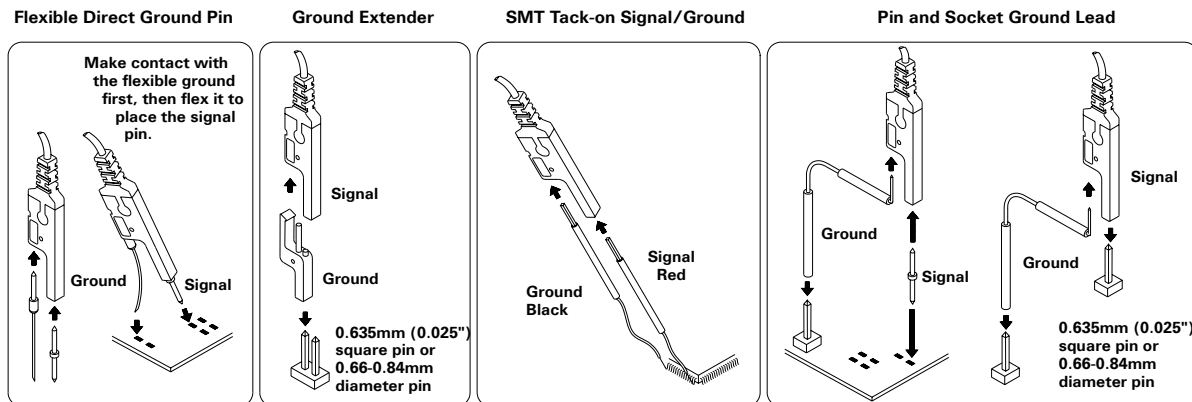


Figure 66. Probing configurations that give the best signal fidelity

Ordering Information

Accessories Supplied with Logic Analyzers

Accessories Supplied with Agilent 16517A/16518A Logic Analyzer Modules

Part Number	Description	Quantity	Page Number
16517-68701	4 GHz timing modules master accessory kit (includes items below)	1	46
16515-27601	Ground connector	2	46
16517-61602	Probe lead assembly	1	46
16517-61604	BNC-SMB adapter cable	1	46
16517-63201	Calibration pod	1	46
16517-82104	SMT lead kit (package of 4 black and 4 red)	1	46
16517-82105	Ground extender kit (package of 20)	1	46
16517-82106	Ground lead kit (package of 20)	1	46
16517-82107	Pin probe kit (package of 4)	1	46
16517-82109	SMD IC clip kit (package of 20)	1	46

Accessories Supplied with Agilent 16557D Logic Analyzer Modules

Part Number	Description	Quantity	Page Number
01650-61608	16-channel probe lead set	4	9
01650-94312	Logic analyzer probe labels	1	13
5090-4833	SMD IC clips, surface mount (package of 20)	4	10
5959-9333	Probe leads, gray (package of 5)	1	9
5959-9334	Short ground leads (package of 5)	4	9
16555-61601	Master/expander interconnect cable	1	not shown

Accessories Supplied with Agilent 1670G Series Logic Analyzers

Part Number	Description	Quantity	Page Number
01650-61608	16-channel probe lead set	8 (1670G), 6 (1671G) 4 (1672G), 2 (1673G)	9
01670-94307	Logic analyzer probe labels	1	13
5090-4833	SMD IC clips, surface mount (package of 20)	8 (1670G), 6 (1671G) 4 (1672G), 2 (1673G)	10
5959-9334	Short ground leads (package of 5)	1	9

Accessories Supplied with Agilent 16710A/16711A/16712A Logic Analyzer Modules

Part Number	Description	Quantity	Page Number
01650-61608	16-channel probe lead set	6	9
01650-94312	Logic analyzer probe labels	1	13
5090-4833	SMD IC clips, surface mount (package of 20)	6	10
5959-9333	Probe leads, gray (package of 5)	1	9
5959-9334	Short ground leads (package of 5)	6	9
16555-61601	Master/expander interconnect cable	1	not shown

Accessories Supplied with Agilent 16715A/16716A/16717A/16740A/16741A/16742A/16750A/B/16751A/B/16752A/B Logic Analyzer Modules

Part Number	Description	Quantity	Page Number
01650-61608	16-channel probe lead set	4	9
01650-94312	Logic analyzer probe labels	1	13
5090-4833	SMD IC clips, surface mount (package of 20)	4	10
5959-9333	Probe leads, gray (package of 5)	1	9
5959-9334	Short ground leads (package of 5)	4	9

Accessories Supplied with Agilent 1680 and 1690 Series Logic Analyzers

Part Number	Description	Quantity	Page Number
01650-61608	16-channel probe lead set	8 (1680A/AD, 1690A/AD), 6 (1681A/AD, 1691A/AD) 4 (1682A/AD, 1692A/AD), 2 (1683A/AD, 1693A/AD)	9
01680-94313	Logic analyzer probe labels	1	13
5090-4833	SMD IC clips, surface mount (package of 20)	8 (1680A/AD, 1690A/AD), 6 (1681A/AD, 1691A/AD) 4 (1682A/AD, 1692A/AD), 2 (1683A/AD, 1693A/AD)	10
5959-9334	Short ground leads (package of 5)	8 (1680A/AD, 1690A/AD), 6 (1681A/AD, 1691A/AD) 4 (1682A/AD, 1692A/AD), 2 (1683A/AD, 1693A/AD)	9

Ordering Information

State ≤ 400 MHz/Timing ≤ 800 MHz

General-Purpose Probing^{1,2}

Probe Leads and Lead Sets

Part Number	Description	Page Number
01650-61608	16-channel probe lead set	9
5959-9333	Probe leads, gray (package of 5)	9
5959-9334	Short ground leads (package of 5)	9
5959-9335	Long ground leads (package of 5)	9

Probe Cables

Part Number	Description	Page Number
01660-61605	For 16550A logic analyzers	11
16555-61606	For 16554A, 16555A/D, 16556A/D logic analyzers	11
16710-61603	For 16557D, 16710A, 16711A, 16712A, and 16706 series logic analyzers	11
16715-61601	For 16715A, 16716A, 16717A, 16718A, 16719A, 16750A/B, 16751A/B, 16752A/B, 1680 and 1690 series logic analyzers	11

IC Clips

Part Number	Description	Page Number
5959-0288	Through-hole IC clip kit, (package of 20)	10
5090-4833	SMD IC clip kit, (package of 20)	10
10467-68701	0.5 mm IC clip kit (package of 4)	10

IC Test Clips

Product Number	Description	Page Number
E2421A	SOIC test clip kit (Pomona 5514), small outline	10
E2422A	QUAD test clip kit (Pomona 5515), four-sided small outline	10

Wedge Adapters

Product Number	Description	Page Number
E2613A	0.5 mm probe adapter-3 signal	12
E2613B	0.5 mm probe adapter-3 signal-2 pack	12
E2614A	0.5 mm probe adapter-8 signal	12
E2643A	0.5 mm probe adapter - 16-signal	12
E2615A	0.65 mm probe adapter-3 signal	12
E2615B	0.65 mm probe adapter-3 signal-2 pack	12
E2616A	0.65 mm probe adapter-8 signal	12
E2644A	0.65 mm probe adapter -16-signal	12

Miscellaneous Probing Accessories

Part Number	Description	Page Number
01650-94303	Logic analyzer probe labels	13
16555-60001	Ferrite core assembly	13

¹ Check on page 36 for accessories supplied with a specific logic analyzer.

² Individual flying lead probes are not available for the 16760A.

Ordering Information

State \leq 400 MHz/Timing \leq 800 MHz

Elastomeric Probing for QFP Packages

Product Number	Description	Page Number
E5336A	144-pin 0.5 mm TQFP elastomeric probe adapter ¹	14-16
E5336A 201	Retainer kit (5 retainers and adhesive)	14-16
E5336A 202	Locator tool	14-16
E5340A	1/4 flex adapter for use with the E5336A (quantity 1)	14-16
E5377A	160-pin 0.5 mm TQFP elastomeric probe adapter ¹	14-16
E5377A 201	Retainer kit (5 retainers and adhesive)	14-16
E5377A 202	Locator tool	14-16
E5349A	1/4 flex adapter for use with the E5377A (quantity 1)	14-16
E5348A	176-pin 0.5 mm TQFP elastomeric probe adapter ¹	14-16
E5348A 201	Retainer kit (5 retainers and adhesive)	14-16
E5348A 202	Locator tool	14-16
E5349A	1/4 flex adapter for use with the E5348A (quantity 1)	14-16
E5361A	144-pin 0.65 mm PQFP/CQFP elastomeric probe adapter ¹	14-16
E5361A 201	Retainer kit (5 retainers and adhesive)	14-16
E5361A 202	Locator tool	14-16
E5340A	1/4 flex adapter for use with the E5361A (quantity 1)	14-16
E5373A	160-pin 0.65 mm PQFP/CQFP elastomeric probe adapter ¹	14-16
E5373A 201	Retainer kit (5 retainers and adhesive)	14-16
E5373A 202	Locator tool	14-16
E5349A	1/4 flex adapter for use with the E5373A (quantity 1)	14-16
E5374A	208-pin 0.5 mm PQFP/CQFP elastomeric probe adapter ¹	14-16
E5374A 201	Retainer kit (5 retainers and adhesive)	14-16
E5374A 202	Locator tool	14-16
E5371A	1/4 flex adapter for use with the E5374A (quantity 1)	14-16
E5363A	240-pin 0.5 mm PQFP/CQFP elastomeric probe adapter ¹	14-16
E5363A 201	Retainer kit (5 retainers and adhesive)	14-16
E5363A 202	Locator tool	14-16
E5371A	1/4 flex adapter for use with the E5363A (quantity 1)	14-16

¹ Each probe adapter includes 5 retainers, 1 locator tool, and adhesive.

Ordering Information

State \leq 400 MHz/Timing \leq 800 MHz

Isolation Adapters and Connectors for Analysis Probes

Normal-Density, Medium-Performance Applications

Part Number	Description	Page Number
01650-63203	100 k ohm isolation adapter	18
1251-8106	20-pin connector	18
1251-8473	20-pin right angle connector	not shown
1251-8828	40-pin, low profile connector (straight)	20-21
1251-8158	40-pin, low profile connector (right angle)	not shown
1251-8831	40-pin connector with latches (straight)	not shown
1251-8931	40-pin connector with latches (right angle)	not shown
5062-7396	Isolation network, surface mount (quantity 1)	21

High-Density, High-Performance Applications

Part/Product Number	Description	Page Number
E5339A	38-Pin low-voltage probe	23-25
E5346A	38-Pin probe	23-25
E5351A	38-pin adapter cable	27-28
E5385A	100-pin probe	23-26
5062-7396	Isolation network, surface mount (quantity 1)	21, 28
E5346-44701	Mictor connector support shroud for PC boards up to 0.062" thick	29
E5346-68701	Mictor connector kit (5 connectors and 5 shrouds) for PC boards up to 0.062" thick	29
E5346-44704	Mictor connector support shroud for PC boards up to 0.125" thick	29
E5346-68700	Mictor connector kit (5 connectors and 5 shrouds) for PC boards up to 0.125" thick	29
E5346-44703	Mictor connector support shrouds for PC boards up to 0.170" thick	29
E5346-60002	Mictor break-out adapter	30
E5346-63201	High-density right-angle adapter	31

Ordering Information

State > 400 MHz/Timing > 800 MHz

16760A 1.5 Gb/s Logic Analysis Module, and 16753A, 16754A, 16755A, and 16756A 600 MHz Logic Analysis Modules

Part/Product Number	Description	Page Number
E5378A	100-Pin single-ended probe for Logic Analyzers with 90-pin pod connectors	36
E5379A	100-Pin differential probe for Logic Analyzers with 90-pin pod connectors	36
E5380A	38-Pin single-ended probe for Logic Analyzers with 90-pin pod connectors	32
E5381A	Differential flying lead probe set for analyzers with 90-pin pod connectors	42
E5382A	Single-ended flying lead probe set for Logic Analyzers with 90-pin pod connectors	34
E5386A	Half-channel probe adapter for 16760A	37
E5387A	Differential soft touch probe for analyzers with 90-pin pod connectors	32
E5390A	Single-ended soft touch probe for analyzers with 90-pin pod connectors	32
E5346-68700	Probing connector kit for E5380A	38
E5346-68701	Probing connector kit for E5380A	38
E5387-68701	Kit of 5 retention modules for E5387A, E5390A	33
16760-68702	Kit of 5 mating connectors and 5 support shrouds for E5385A, E5378A and E5379A, for PC boards up to 0.062" thick	38
16760-68703	Kit of 5 mating connectors and 5 support shrouds for E5385A, E5378A and E5379A, for PC boards up to 0.120" thick	38
16760-02302	Support shroud for E5385A, E5378A and E5379A, for PC boards up to 0.062" thick	38
16760-02303	Support shroud for E5385A, E5378A and E5379A, for PC boards up to 0.120" thick	38
1253-3620	100-pin mating connector for E5378A, E5385A, and E5379A	38

16517A/18A High-Speed Logic Analysis Modules

General-Purpose Probes

Part/Product Number	Description	Page Number
16517-61602	Probe lead assembly	46
16517-61604	BNC-SMB adapter cable	46
16517-63201	Calibration pod	46
16517-68701	4 GHz timing modules master accessory kit	46
16517-82104	SMT lead kit (package of 4 black and 4 red)	46
16517-82105	Ground extender kit (package of 20)	46
16517-82106	Ground lead kit (package of 20)	46
16517-82107	Pin probe kit (package of 4)	46
16517-82109	SMD IC clip kit (package of 20)	46
16518-68701	Expansion module accessory kit	46
5081-7753	Probe lead kit (set of 3 ea. 16517-61602)	46
E5320-26101	Flexible ground pin	45
16517-27601	SMA to probe tip adapter	45
E9638A	BNC to probe tip adapter	45
16515-27601	Ground connector	42

Related Information

Agilent Technologies logic analysis third-party partners:

For a complete list of partners, see document 5966-4365EUS "Processor and Bus Support for Agilent Technologies Logic Analyzers."

3M

<http://www.mmm.com/interconnects>

AMP, Inc.

Phone: 1-717-986-7777

Fax: 1-717-986-7575

Phone (USA only): 1-800-522-6752

E-mail: product.info@amp.com

Web site: <http://www.amp.com>

Agilent Technologies Test and Measurement Organization support line phone number:
1-800-452-4844

Agilent Technologies Test and Measurement Organization web site:
<http://www.agilent.com>

Agilent Technologies Test and Measurement Logic Analyzers-Systems web site:

<http://www.agilent.com/find/lasystems>

Agilent Technologies Test and Measurement Logic Analyzers-Benchtop web site:

<http://www.agilent.com/find/LAbenchtops>

Agilent Technologies Test and Measurements Accessories web site:

<http://www.agilent.com/find/LAccessories>

For custom probing accessories not listed in this document, Agilent recommends that you contact:

JM Engineering

3502 E. Boulder

Colorado Springs, CO 80909

Phone: 1-719-591-1119

Web site: <http://www.jmecorp.com>

This document does not cover the following topics:

- Pattern generator probing and accessories

See: *Agilent Technologies 16700 Series Logic Analysis System, Product Overview*, publication

number 5968-9661E

- Analysis probes for processors and buses

See: *Processor and Bus Support for Agilent Technologies Logic Analyzers, Configuration Guide*, publication number 5966-4365E

- Emulation probes

See: *Processor and Bus Support for Agilent Technologies Logic Analyzers, Configuration Guide*, publication number 5966-4365E

- Oscilloscope probes and accessories

See: *Agilent Technologies 16700 Series Logic Analysis System, Product Overview*, publication number 5968-9661E

Agilent Technologies' Test and Measurement Support, Services, and Assistance

Agilent Technologies aims to maximize the value you receive, while minimizing your risk and problems. We strive to ensure that you get the test and measurement capabilities you paid for and obtain the support you need. Our extensive support resources and services can help you choose the right Agilent products for your applications and apply them successfully. Every instrument and system we sell has a global warranty. Support is available for at least five years beyond the production life of the product. Two concepts underlie Agilent's overall support policy: "Our Promise" and "Your Advantage."

Our Promise

Our Promise means your Agilent test and measurement equipment will meet its advertised performance and functionality. When you are choosing new equipment, we will help you with product information, including realistic performance specifications and practical recommendations from experienced test engineers. When you use Agilent equipment, we can verify that it works properly, help with product operation, and provide basic measurement assistance for the use of specified capabilities, at no extra cost upon request. Many self-help tools are available.

Your Advantage

Your Advantage means that Agilent offers a wide range of additional expert test and measurement services, which you can purchase according to your unique technical and business needs. Solve problems efficiently and gain a competitive edge by contracting with us for calibration, extra-cost upgrades, out-of-warranty repairs, and on-site education and training, as well as design, system integration, project management, and other professional engineering services. Experienced Agilent engineers and technicians worldwide can help you maximize your productivity, optimize the return on investment of your Agilent instruments and systems, and obtain dependable measurement accuracy for the life of those products.



Agilent Email Updates

www.agilent.com/find/emailupdates

Get the latest information on the products and applications you select.

Agilent T&M Software and Connectivity

Agilent's Test and Measurement software and connectivity products, solutions and developer network allows you to take time out of connecting your instruments to your computer with tools based on PC standards, so you can focus on your tasks, not on your connections. Visit www.agilent.com/find/connectivity for more information.

By internet, phone, or fax, get assistance with all your test & measurement needs

Online assistance:
www.agilent.com/find/assist

Phone or Fax
United States:
(tel) 800 452 4844

Canada:
(tel) 877 894 4414
(fax) 905 282 6495

China:
(tel) 800 810 0189
(fax) 800 820 2816

Europe:
(tel) (31 20) 547 2323
(fax) (31 20) 547 2390

Japan:
(tel) (81) 426 56 7832
(fax) (81) 426 56 7840

Korea:
(tel) (82 2) 2004 5004
(fax) (82 2) 2004 5115

Latin America:
(tel) (305) 269 7500
(fax) (305) 269 7599

Taiwan:
(tel) 0800 047 866
(fax) 0800 286 331

Other Asia Pacific Countries:
(tel) (65) 6375 8100
(fax) (65) 6836 0252
Email: tm_asia@agilent.com

Product specifications and descriptions in this document subject to change without notice.

© Agilent Technologies, Inc. 2003
Printed in USA March 27, 2003
5968-4632E

